



Terex Lifting Australia Pty. Ltd.

RATED CAPACITY MANUAL

MODEL MAC 25

16.6t REAR AXLE WEIGHT
BOOK PART NUMBER MXC1347B

HYDRAULIC ALL TERRAIN PICK & CARRY CRANE

25 TONNE MAXIMUM RATED CAPACITY

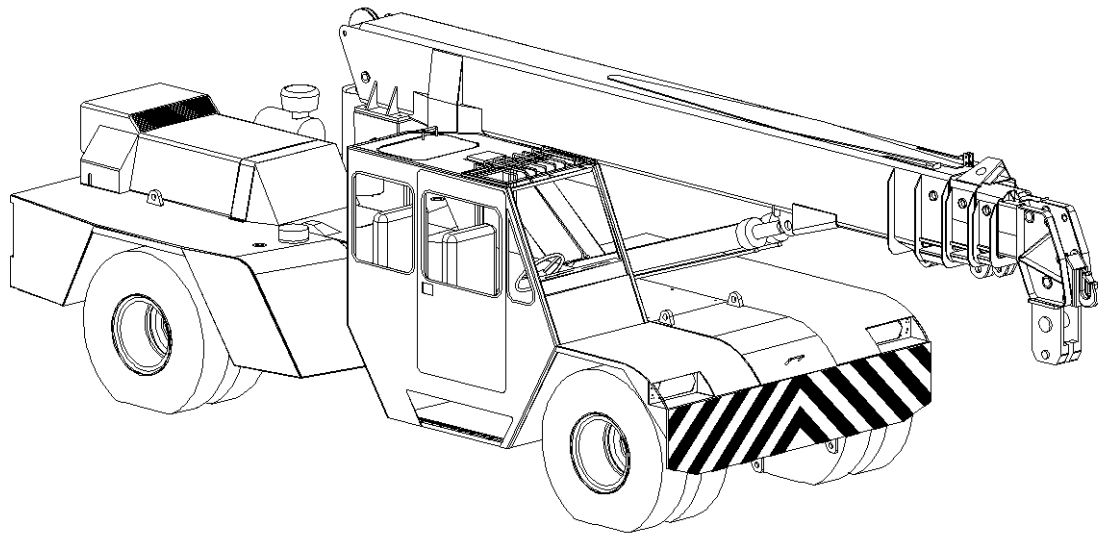

Do not operate this crane unless you have read and understood the information in this book.

**MXC1347B
 RATED CAPACITY MANUAL
 MAC 25 (STANDARD 1500kg COUNTERWEIGHT + EXTRA
 2160kg COUNTERWEIGHT)**

ALL PAGES LISTED MUST BE INCLUDED IN THIS BOOK.

SECTION 1 - WARNINGS..... 3
 DEFINITIONS 4
 OPERATION ON SIDE SLOPES 8
 SIDE SLOPE DERATION CHART 9
SECTION 2 - OPERATIONS 11
 RANGE DIAGRAM 11
 WORKING AREA DIAGRAM 11
 DETACHABLE COUNTERWEIGHT 12
 ATTACHMENT MASSES 12
 HOOK BLOCK RATED CAPACITY 12
 ROPE SPECIFICATIONS..... 13
 TYRE SPECIFICATIONS 13
 TYRE INFLATION 13
SECTION 3 – LIFTING CAPACITY..... 14
 RANGE DIAGRAM 14
LOAD MOMENT INDICATOR DUTIES..... 15
 1500 kg COUNTERWEIGHT ON FRONT 15
 1500 kg COUNTERWEIGHT ON REAR 15
 1500+2160 kg COUNTERWEIGHT ON REAR 15

SECTION 1 - WARNINGS

 **DANGER**

IMPROPER CRANE USE, CARE OR OPERATION CAN CAUSE INJURY, DEATH OR PROPERTY DAMAGE.

DO NOT OPERATE THIS MACHINE UNLESS YOU HAVE READ AND UNDERSTAND THE OPERATOR'S MANUAL AND CRANE RATED CAPACITY MANUAL.

COPIES OF OPERATOR'S MANUALS AND CRANE RATED CAPACITY MANUAL MAY BE OBTAINED FROM:



 **CAUTION**

WRITTEN AUTHORISATION IS REQUIRED FROM TEREX LIFTING AUSTRALIA PTY LTD PRIOR TO THE USE OF ANY ATTACHMENT NOT SPECIFIED IN THE MANUAL.

DEFINITIONS

Articulation – The crane pivots in the middle to allow steering and slewing of the load. Working Areas for the purpose of determining Rated Capacity are less than 10° Articulation, and greater than 10° Articulation, in either direction, from straight ahead. Up to 40° Articulation is possible in either direction. See Working Area diagram

Deration – A decrease in the Rated Capacity due to external influences, expressed as a percentage.

Freely Suspended Load – Load hanging free with no direct external force applied except by the winch rope.

Load Radius – Horizontal distance from the centre of the front wheels forwards to the centre of the winch rope or tackle with load applied. “Radius” on Rated Capacity charts refers to the Load Radius in metres.

Loaded Boom Angle – This is given to assist in setting up the crane only. It gives only an approximation of the Load Radius for a specified boom length. No allowance is made for boom or tyre deflection. “Boom Angle” on Rated Capacity charts refers to the Loaded Boom Angle in degrees.

Load Moment Indicator (LMI) - A system which indicates, visually and audibly, to the operator when the Rated Capacity is approached and reached.

Rated Capacity (RC) – The total Freely Suspended Load, including the mass of material and load handling equipment, that the machine can safely lift under ideal conditions at a given boom length and Load Radius.

Side Load – Any external force applied either to the boom or load in a horizontal direction.

Work Areas – Area measured in an arc about the centre pivot as shown on the Working Area diagram. The “Articulation (green/amber)” icon on the LMI indicates which zone the crane is in. Green indicates less than 10° Articulation. Amber indicates greater than 10° Articulation.



SPECIAL PRECAUTIONS FOR ARTICULATED CRANES

THERE IS A POTENTIAL FOR CRUSHING BETWEEN FRONT AND REAR CHASSIS WHEN THE MACHINE ARTICULATES. NEVER STAND IN THE PIVOT AREA WHEN THE ENGINE IS RUNNING OR EMERGENCY STEERING PUMP IS OPERATING. ALWAYS REMOVE THE KEY FROM THE IGNITION BEFORE WORKING IN THE PIVOT AREA.

DO NOT LEAVE IGNITION KEY SWITCHED ON WITH ENGINE STOPPED AND PARK BRAKE OFF, AS EMERGENCY HYDRAULIC STEERING PUMP WILL ACTIVATE.

GENERAL

1. This machine has been designed to meet the requirements of AS1418.1 & 1418.5 and has been tested in accordance with these standards for pick and carry operation on tyres.
2. Rated Capacities shown are for this machine as originally manufactured by Terex Lifting Australia Pty Ltd. The Rated Capacities only apply when all the instructions in this book are rigidly followed. Modifications to this machine or use of equipment other than that specified can result in a reduction in Rated Capacity.
3. If improperly operated or maintained, this machine can be hazardous. Operation and maintenance of this machine must be in compliance with the information documented in the operators, service and parts manuals furnished. If these manuals are missing, obtain replacements through Terex Lifting Australia Pty Ltd or their agents.
4. This machine is classified C3.

SET-UP

1. Reduced crane Rated Capacities for the particular job shall be established, by the operator, with due allowance for adverse operating conditions. These conditions include the supporting surface, pendulum action of the load, jerking or sudden stops of the load and other factors affecting stability, two machine lifts, electrical wires, adverse weather, wind, hazardous surroundings, experience of personnel, etc.
2. Rated Capacity is based on Freely Suspended Loads with the machine on a firm, level (max. 1% slope / 0.6°) and uniform surface. Lifting, or travelling with a load, on soft or uneven ground can be hazardous and will reduce the Rated Capacity of the crane. Refer to the "OPERATION ON SIDE SLOPES" in this manual. No attempt shall be made to drag the load along the ground in any direction.
3. Wind forces on the boom, resulting from winds up to 10 m/s (36 km/h), are incorporated in the Rated Capacity. Any additional Side Loading due to wind forces on the load will reduce the Rated Capacity, and must be considered.

DANGER

4. Rated Capacities above the red line are based on the machine's hydraulic or structural competence and not on machine stability. Rated Capacities below the red line are based on machine stability.
5. Rated Capacities include the mass of hooks, blocks, slings and auxiliary lifting devices. Their mass must be subtracted, from the listed Rated Capacity, to determine the equivalent net load.
6. Loaded Boom Angles at specified boom lengths give only an approximation of the Load Radius. The Boom Angle before loading should be greater to account for boom deflection increasing the Load Radius as the load is lifted.

OPERATION

1. Read and understand all warnings and instructional notes.
2. Do not tip the machine to determine allowable lifting capacities.
3. Loads may be lifted from the main boom head on the winch, the rhino hook, the fixed lug, or either of the two sliding lugs on the boom. A flyjib is also available to extend the maximum boom length and a manbasket can be pinned to the head of the boom. Always use the correct Rated Capacity chart for the lifting point in use and ensure the LMI is set to the correct duty. Written authorisation from Terex Lifting Australia Pty Ltd is required prior to the use of any attachment not specified in the manual.
4. Lifting from more than one lifting point simultaneously is neither intended nor approved.
5. Handling of personnel from the boom is neither intended nor approved, except in a Terex Lifting Australia supplied manbasket, correctly installed on the head of the boom, or other approved arrangement.
6. When either the boom length or Load Radius or both are between values listed, the smallest load shown at either the next larger Load Radius or boom length shall be used, or the interpolated value shown on the LMI may be used.
7. Side Loading of the machine and load swing out may cause structural failure or machine tip-over. Side Loads may be generated by: lifting when not level; sudden acceleration or deceleration in Articulating with a load; dragging a load; pushing a load; wind forces on load and boom structure and unstable ground.
8. It is safe to attempt to telescope any load within the limits of the Rated Capacity Manual. The maximum load that may be telescoped is limited by hydraulic pressure, Loaded Boom Angle and powered boom sections lubrication.



CAUTION

9. The winch rope is fully compensated for boom extension. The only exception is when the third extension is being used. Refer to the operator's manual for information on the use of the third extension.
10. Do not allow the winch rope to unwind fully. Always ensure a minimum of 2 wraps of rope remain on the winch drum. Note the areas on the range diagram where the fall block cannot reach the ground on 6 parts of rope.
11. Rated Capacity depends on tyre rating, tyre condition and tyre inflation pressure. All tyres must be in good condition and must be inflated to the recommended pressure before attempting a lift.
12. Pick & carry operation is permitted through the full Articulation range, however, Rated Capacity is reduced above 10° Articulation. Use the reduced capacities in the rated capacity chart if entering this Articulation zone during the operation.
13. The maximum speed for pick & carry operation is 0.4m/s (1.44km/h). The transfer case shall be set to low range.
14. Operation of this crane in excess of the Rated Capacity and disregard of the instructions is hazardous.

OPERATION ON SIDE SLOPES

Mobile Cranes are primarily designed to be used on firm, flat, level ground (to within 1% gradient), according to AS 1418.5, any deviation from this requires that the Rated Capacity shall be reduced accordingly. As per AS 2550.5 – negotiation of slopes by mobile cranes travelling with Freely Suspended Loads should be avoided. The following precautions should be taken when operating on side slopes of up to 5° (8.75% gradient) – **REMEMBER** surface depressions and potholes will create the same effect as a side slope.

Ensure the tyres are correctly **INFLATED** as per the rated capacity manual.

Ensure the ground condition is **FIRM** enough to support the axle loads.

REDUCE the Rated Capacity of the crane by the percentage value for the crane as shown in figure 1 for operating on side slopes up to 5° (8.75% gradient) - **REMEMBER** the crane's load moment indicator will **NOT** automatically derate the Rated Capacity.

Use the crane's side slope inclinometer as a guide only, it is most accurate when the crane's Articulation is straight ahead without suspending a load. All Articulated chassis cranes will show some degree of side tilt, when Articulated with a load – this should not be confused with the ground's side slope.

Use the **MINIMUM** boom length and Loaded Boom Angle practical to keep the boom tip as close to the ground as possible.

Keep the load as **CLOSE** to the ground as possible.

Use the **MINIMUM** Articulation angle practical - **REMEMBER** the crane will side tilt and hence the hook will move towards the direction of Articulation whilst steering.

Keep the load on the **UPHILL** side of the crane where possible, especially when Articulated – **REMEMBER** the working Load Radius will increase if the load is suspended in the downhill position.

Load swing greatly reduces stability – **REMEMBER** to tagline loads to prevent pendulum motion of the load. Travel and crane motions should be applied gently to minimise this effect.

Sudden acceleration or deceleration of suspended load can also reduce stability – **REMEMBER** to travel gently to reduce load swing.

SIDE SLOPE DERATION CHART

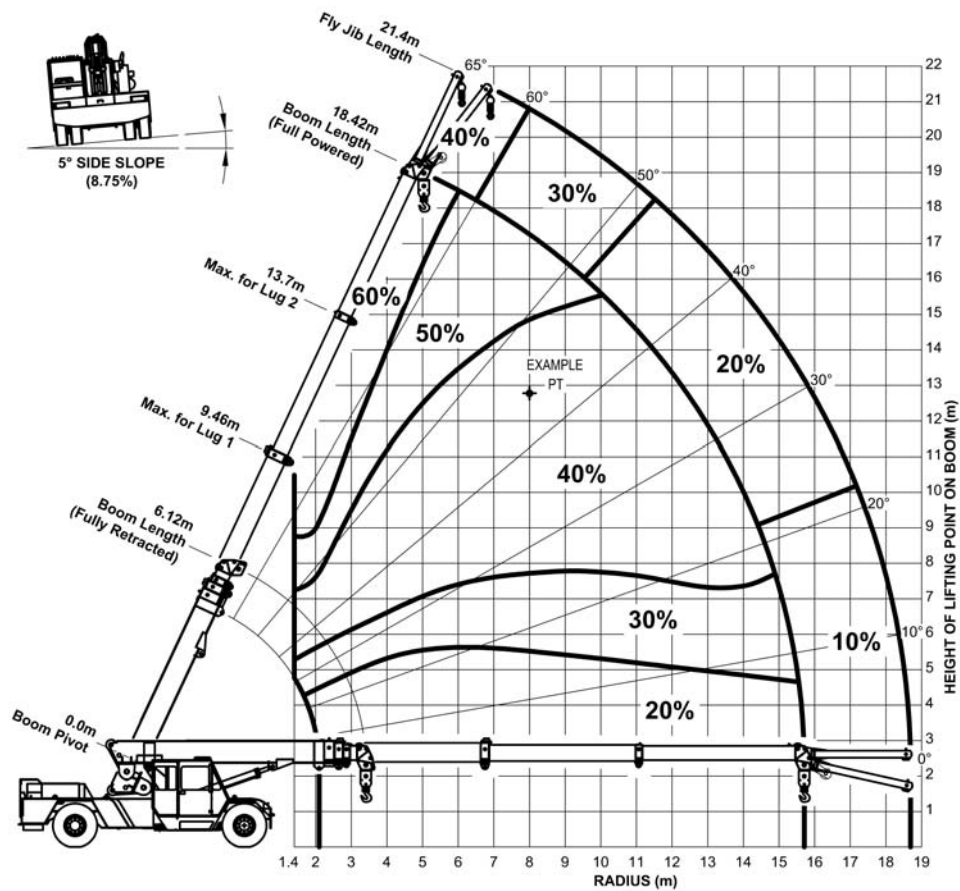

Figure 1: Percentage Deration Chart for MAC 25 at 5° Side Slope

NOTE

1. Percentage deration chart is based on 66.6% stability as per AS 1418.5 with the crane on a firm side slope of 5° (8.75% Gradient).
2. The percentage deration is dependent upon the location of the lifting point on the boom.
3. The percentage deration should be applied to the Rated Capacity as read off the Rated Capacity chart for the applicable boom length, Loaded Boom Angle, Load Radius, Articulation Angle and Counterweight Position. See over page for an example.

Example (For MAC 25 Crane, Rated Capacity manual MXC1347B): See Percentage Deration Chart for

Lifting condition:-

Boom Length:	15.0 m
Loaded Boom Angle:	45°
Load Radius:	8.0 m
Articulation Angle:	Greater than 10°
Counterweight:	Fitted on rear of crane

RC (Level ground):	3700 kg (From Load Chart MXC1268A, for above lifting conditions)
--------------------	--

Percentage Deration:	40 % (From Figure 1: Percentage Deration Chart)
----------------------	---

$$\begin{aligned} \text{RC (5° Slide Slope)} &= \text{RC (as per Rated Capacity chart)} - \text{Percentage Deration} \\ &\quad \times \text{RC (as per Rated Capacity chart)} / 100 \% \\ &= 3700 \text{ kg} - 40\% \times 3700 \text{ kg} / 100\% \\ &= 2220 \text{ kg} \end{aligned}$$

SECTION 2 - OPERATIONS

RANGE DIAGRAM

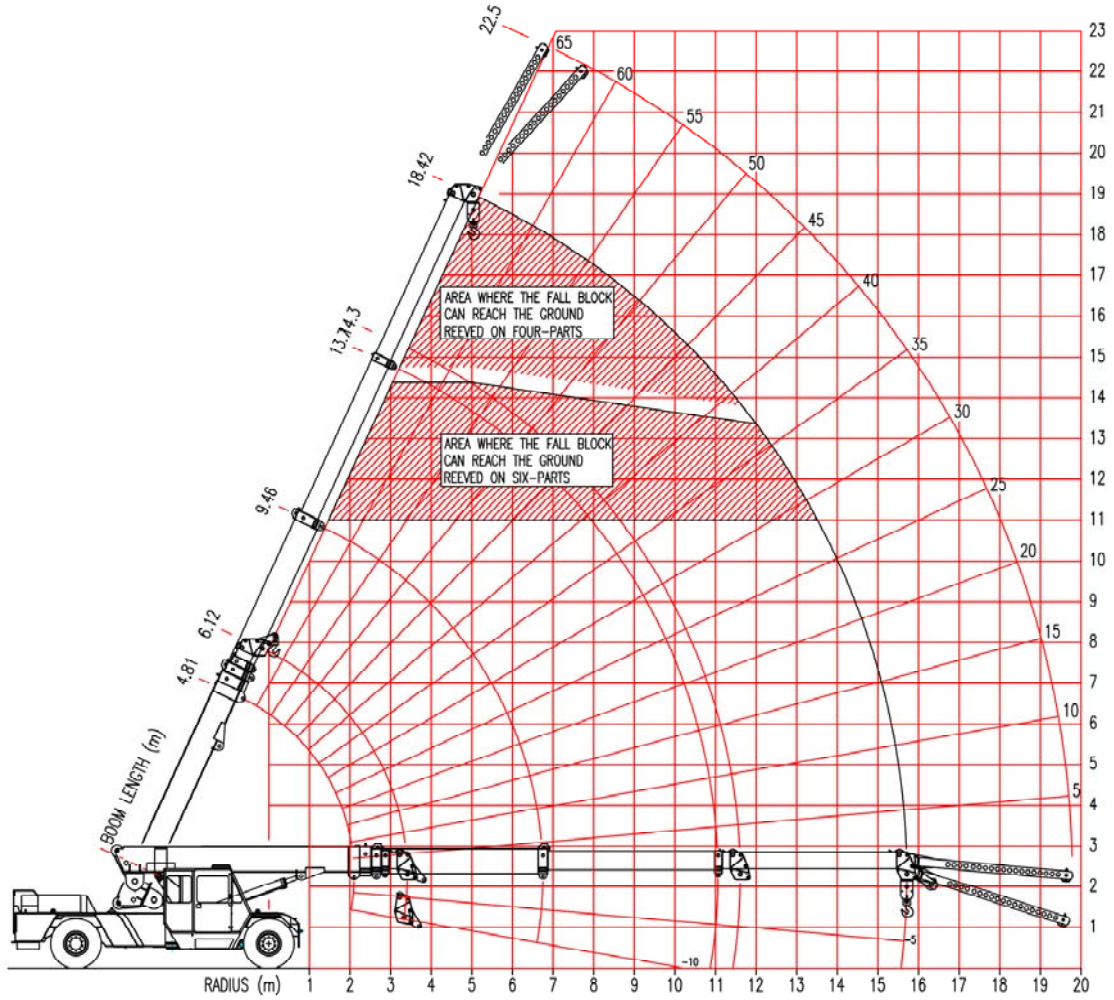

WORKING AREA DIAGRAM

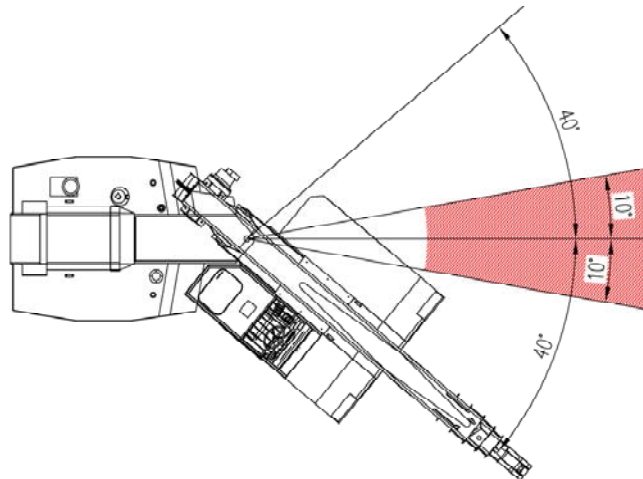

DETACHABLE COUNTERWEIGHT

WEIGHT: 1500kg

TO BE FRONT MOUNTED FOR ROAD TRAVEL

PART NO: PLMXF2034

EXTRA COUNTERWEIGHT: 2160kg

NOT TO BE FITTED FOR ROAD TRAVEL

PART NO: PLMXF2019

ATTACHMENT MASSES

FOUR/SIX PART FALL BLOCK	PLMXA3018	180 kg
FOUR/SIX PART FALL BLOCK	PLMXA3033	230 kg
25 T HOOK	PP2087500	20 kg
9 T HOOK	PP2190200	10 kg
SINGLE PART HOOK BLOCK	PL16M2090	30 kg
RHINO HOOK	PLMXF3015	25 kg
12 METRIC TONNE SPREADER BAR	PL16A3035	94 kg
15 METRIC TONNE SPREADER BAR	PL15A8023	107 kg

NOTE: THESE MASSES APPLY ONLY TO TEREX LIFTING AUSTRALIA PTY LTD SUPPLIED EQUIPMENT.

HOOK BLOCK RATED CAPACITY

Number of Parts of Rope	Permissible HOOK BLOCK RC (kg)
1	4 200
2	8 400
4	16 800
6	25 000

ROPE SPECIFICATIONS

WIRE ROPE:

Ø14mm

35W x 7 NR 2070 MPa

MINIMUM BREAKING FORCE 165 kN

MACHINE SPLICE & THIMBLE EYE ONE END ONLY

LENGTH - 110m

RETRACT ROPE:

Ø11mm

6 x 25 WRC G2070

MINIMUM BREAKING FORCE 82.4kN

EXTENSION CHAIN:

BL1066 LEAF CHAIN

MINIMUM BREAKING FORCE 40 000 KGF

TYRE SPECIFICATIONS

Type	Condition	Speed	Load Rating
14.00 x 20 Dual Tyres	Pick & Carry	<1.44 km/h	10500 kg per tyre at 830 kPa (120 psi) (dual fitment)
	Highway	80 km/h	3050 kg per tyre at 620 kPa (90 psi) (dual fitment)

TYRE INFLATION

Type	Position	Inflation Pressure	
		Pick & Carry	Highway Travel
14.00 x 20 Dual Tyres	Front	830 kPa (120 psi) (Max RC 25 tonne)	830 kPa (120 psi)
	Rear	620 kPa (90 psi)	620 kPa (90 psi)

SECTION 3 – LIFTING CAPACITY

RANGE DIAGRAM

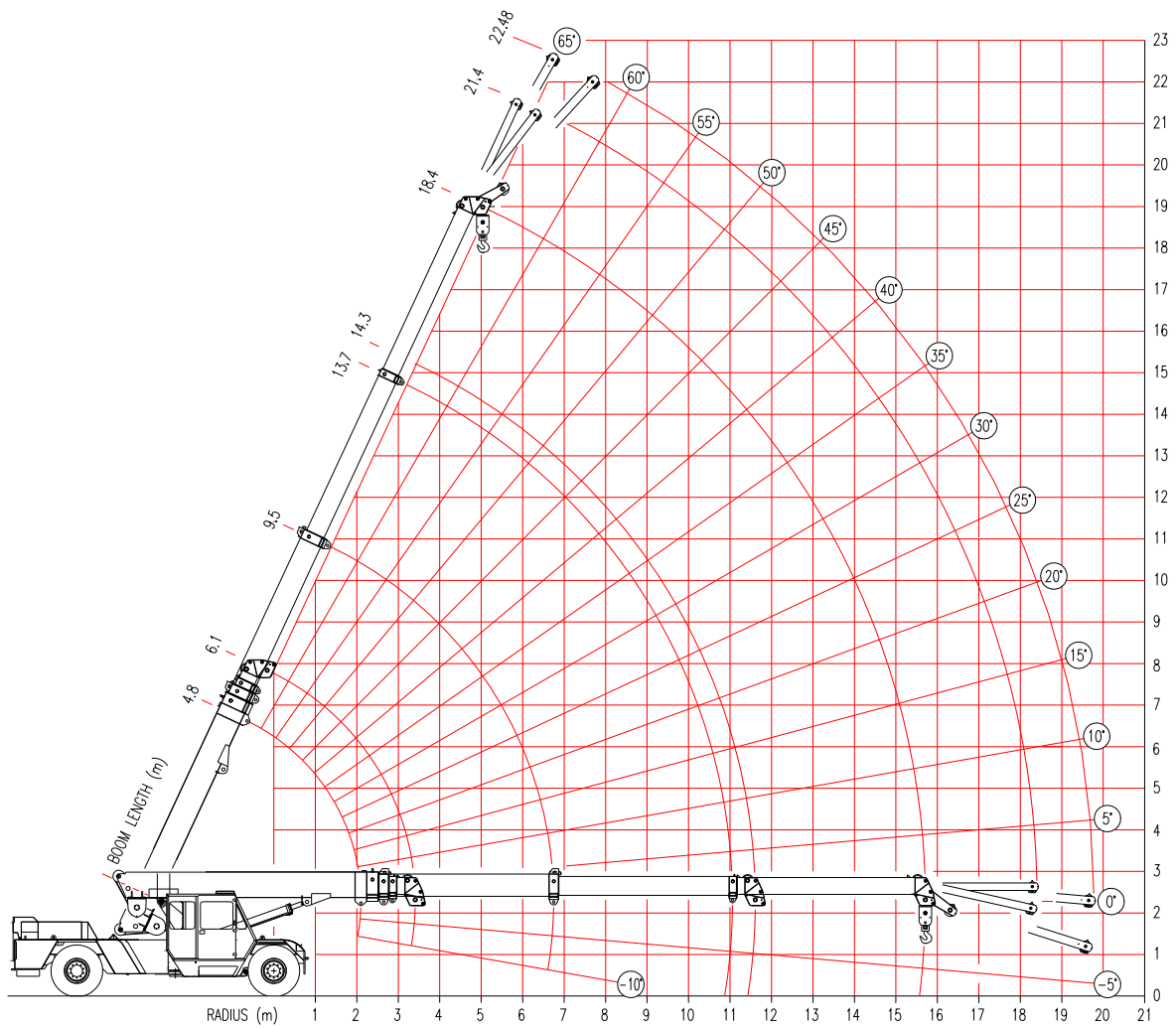

CONDITIONS:
 FRONT SPRING LOCKOUTS TO BE ENGAGED FOR ALL LIFTING AND PICK
 AND CARRY OPERATIONS.

LOAD MOMENT INDICATOR DUTIES

1500 kg COUNTERWEIGHT ON FRONT

DUTY	DESCRIPTION
101	FALL BLOCK
102	RHINO HOOK
103	OFFSET HEAD – BOTTOM POSITION
104	OFFSET HEAD – TOP POSITION
105	3M FLYJIB –TOP POSITION - 0° OFFSET
106	3M FLYJIB –TOP POSITION – 12.5° OFFSET
107	4M FLYJIB – TOP POSITION - 5° OFFSET
108	4M FLYJIB – BOTTOM POSITION – 17.5° OFFSET
109	MAN BASKET
110	BUTT LUG
111	LUG 1 – BOOM 1
112	LUG 2 – BOOM 2

1500 kg COUNTERWEIGHT ON REAR

DUTY	DESCRIPTION
201	FALL BLOCK
202	RHINO HOOK
203	OFFSET HEAD – BOTTOM POSITION
204	OFFSET HEAD – TOP POSITION
205	3M FLYJIB –TOP POSITION - 0° OFFSET
206	3M FLYJIB –TOP POSITION – 12.5° OFFSET
207	4M FLYJIB – TOP POSITION - 5° OFFSET
208	4M FLYJIB – BOTTOM POSITION – 17.5° OFFSET
209	MAN BASKET
210	BUTT LUG
211	LUG 1 – BOOM 1
212	LUG 2 – BOOM 2

1500+2160 kg COUNTERWEIGHT ON REAR

DUTY	DESCRIPTION
301	FALL BLOCK
302	RHINO HOOK
303	OFFSET HEAD – BOTTOM POSITION
304	OFFSET HEAD – TOP POSITION
305	3M FLYJIB –TOP POSITION - 0° OFFSET
306	3M FLYJIB –TOP POSITION – 12.5° OFFSET
307	4M FLYJIB – TOP POSITION - 5° OFFSET
308	4M FLYJIB – BOTTOM POSITION – 17.5° OFFSET
309	MAN BASKET
310	BUTT LUG
311	LUG 1 – BOOM 1
312	LUG 2 – BOOM 2

MAC-25 FALL BLOCK LOAD CHART - 10 DEG. ART.

LMI DUTY **101**

COUNTERWEIGHT ON FRONT OF CRANE - SPRING LOCKOUTS ENGAGED

Yellow Box S.W.L IN KILOGRAMS FOR SLEW ANGLES OF 10 DEGREES OR LESS EITHER SIDE OF STRAIGHT AHEAD (INDICATED BY GREEN LED ON DASH).

White Box BOOM ANGLE - UNDEFLECTED (REF.)

NOTE : VALUES IN BRACKETS () ARE ACTUAL RADIUS AT ZERO DEG. BOOM ANGLE.

S.W.L. ARE BASED ON 66.7% STABILITY & STRENGTH

- S.W.L. ABOVE BOLD RED LINE ARE STRUCTURAL

S.W.L. ARE BASED ON FIRM LEVEL GROUND (1% SLOPE (0.6 DEG) AS PER AS1418.5)

WITH TYRES INFLATED AS PER NOTES

LIFT & CARRY - THE S.W.L. SHALL BE CARRIED WITH THE MINIMUM BOOM LENGTH & AS

CLOSE TO THE GROUND AS POSSIBLE AT SPEEDS NOT IN EXCESS OF 0.4 M/SEC (1.44 KM/HR)

Radius in Metres	BOOM PIVOT TO HEAD SHEAVES - THIRD BOOM RETRACTED (metres)														THIRD BOOM EXTENDING (metres)												
	6.12	6.50	7.00	7.50	8.00	8.50	9.00	9.50	10.00	10.50	11.00	11.50	12.00	12.50	13.00	13.50	14.32	14.50	15.00	15.50	16.00	16.50	17.00	17.50	18.00	18.42	
1.4	23900	23850	23750	23800	23800	23750	23750	23750																			
	48	51	54	57	59	61	63	65																			
2.0	19950	19900	19850	19800	19750	19750	19700	19650	19650	19600	19300																
	40	44	48	51	54	57	59	61	62	64	65																
2.5	15700	15650	15600	15600	15550	15500	15500	15450	15450	15400	15400	15350	14600														
	32	37	42	46	50	52	55	57	59	61	62	63	65														
3.0	12800	12800	12800	12750	12700	12700	12650	12650	12600	12600	12600	12550	12550	12500	12250												
	21	29	35	41	45	48	51	53	55	57	59	61	62	63	64	65											
3.5	11050	10750	10750	10750	10700	10700	10650	10650	10600	10600	10600	10550	10550	10550	10500	10500	10500	10500									
	(3.4)	17	28	34	39	43	47	49	52	54	56	58	59	61	62	63	65	65									
4.0		9750	9200	9200	9200	9150	9150	9150	9100	9100	9100	9050	9050	9050	9000	9000	9000	9000	9050	9100							
		(3.8)	17	27	33	38	42	45	48	51	53	55	56	58	59	61	62	63	64	65							
5.0			8450	7400	7050	7050	7050	7000	7000	7000	6950	6950	6950	6950	6950	6900	6900	6900	6950	7000	7050	7100	7100	7150	7200		
			(4.3)	(4.8)	16	25	31	36	40	43	46	48	50	52	54	56	58	58	59	61	62	63	63	64	65		
6.0					6550	5850	5600	5600	5600	5600	5550	5550	5550	5550	5550	5500	5500	5500	5550	5600	5650	5700	5700	5750	5750	5800	
					(5.3)	(5.8)	15	24	30	34	38	41	44	46	48	50	53	53	55	56	57	58	60	61	61	62	
7.0							5250	4750	4550	4550	4550	4550	4550	4550	4500	4500	4500	4500	4550	4600	4650	4650	4700	4750	4750	4800	
							(6.3)	(6.8)	14	23	28	33	36	39	42	44	48	48	50	52	53	54	56	57	58	59	
8.0									4300	3900	3800	3800	3800	3800	3750	3750	3750	3750	3800	3850	3900	3900	3950	4000	4000	4050	
									(7.3)	(7.8)	14	22	27	31	35	38	42	43	45	47	48	50	51	53	54	55	
9.0											3600	3300	3200	3200	3200	3200	3150	3200	3250	3250	3300	3350	3350	3400	3400	3450	
											(8.3)	(8.8)	13	21	26	30	35	36	39	41	43	45	47	48	50	51	
10													3000	2800	2700	2700	2700	2700	2750	2800	2850	2850	2900	2900	2950	2950	
													(9.3)	(9.8)	12	20	28	29	32	35	38	40	42	44	45	47	
11															2550	2350	2300	2350	2350	2400	2450	2450	2500	2550	2550	2600	
															(10.3)	(10.8)	17	19	24	28	31	34	37	39	41	42	
12																	2100	2050	2050	2100	2100	2150	2200	2200	2250	2250	
																	(11.6)	(11.8)	12	19	23	27	30	33	36	37	
13																			1950	1850	1850	1850	1900	1950	1950	2000	
																			(12.3)	(12.8)	11	18	23	27	30	32	
14																					1750	1650	1650	1700	1700	1750	
																					(13.3)	(13.8)	11	18	22	25	
15																							1600	1500	1500	1550	
																							(14.3)	(14.8)	11	16	
15.71																									1450	1400	
																									(15.3)	(15.7)	

NOTE : WEIGHT OF HOOKS, BLOCKS & OTHER LOAD HANDLING DEVICES SHALL BE ADDED TO THE WEIGHT OF THE LOAD

MAC-25 FALL BLOCK LOAD CHART - 40 DEG. ART.

COUNTERWEIGHT ON FRONT OF CRANE - SPRING LOCKOUTS ENGAGED

LMI DUTY **101**

■ S.W.L IN KILOGRAMS FOR SLEW ANGLES OF GREATER THAN 10 DEGREES UP TO 40 DEGREES EITHER SIDE OF STRAIGHT AHEAD (INDICATED BY RED LED ON DASH).
□ BOOM ANGLE - UNDEFLECTED (REF.)

NOTE : VALUES IN BRACKETS () ARE ACTUAL RADIUS AT ZERO DEG. BOOM ANGLE.

S.W.L. ARE BASED ON 66.7% STABILITY & STRENGTH

- S.W.L. ABOVE BOLD RED LINE ARE STRUCTURAL

S.W.L. ARE BASED ON FIRM LEVEL GROUND (1% SLOPE (0.6 DEG) AS PER AS1418.5)

WITH TYRES INFLATED AS PER NOTES

LIFT & CARRY - THE S.W.L. SHALL BE CARRIED WITH THE MINIMUM BOOM LENGTH & AS

CLOSE TO THE GROUND AS POSSIBLE AT SPEEDS NOT IN EXCESS OF 0.4 M/SEC (1.44 KM/HR)

Radius in Metres	BOOM PIVOT TO HEAD SHEAVES - THIRD BOOM RETRACTED (metres)														THIRD BOOM EXTENDING (metres)											
	6.12	6.50	7.00	7.50	8.00	8.50	9.00	9.50	10.00	10.50	11.00	11.50	12.00	12.50	13.00	13.50	14.32	14.50	15.00	15.50	16.00	16.50	17.00	17.50	18.00	18.42
1.4	23750	22450	20950	19200	17750	16600	15600	14750																		
	48	51	54	57	59	61	63	65																		
2.0	17850	17850	17800	16850	15950	15150	14500	13750	13000	12350	11750															
	40	44	48	51	54	57	59	61	62	64	65															
2.5	14000	14000	13950	13900	13900	13400	12800	12300	11800	11400	10950	10500	10050													
	32	37	42	46	50	52	55	57	59	61	62	63	65													
3.0	11450	11400	11400	11350	11350	11300	11300	10950	10550	10150	9800	9500	9200	8950	8600	8300										
	21	29	35	41	45	48	51	53	55	57	59	61	62	63	64	65										
3.5	9800	9550	9550	9550	9500	9500	9450	9450	9450	9150	8850	8550	8300	8050	7850	7650	7300	7250								
	(3.4)	17	28	34	39	43	47	49	52	54	56	58	59	61	62	63	65	65								
4.0		8650	8150	8150	8150	8100	8100	8050	8050	8000	7750	7550	7350	7150	6950	6650	6650	6500	6400							
		(3.8)	17	27	33	38	42	45	48	51	53	55	56	58	59	61	62	63	64	65						
5.0			7450	6500	6200	6200	6200	6200	6150	6150	6150	6150	6100	6100	6000	5800	5600	5550	5500	5400	5350	5300	5200	5150	5100	
			(4.3)	(4.8)	16	25	31	36	40	43	46	48	50	52	54	56	58	58	59	61	62	63	63	64	65	
6.0					5750	5100	4900	4900	4900	4900	4850	4850	4850	4850	4850	4850	4750	4750	4700	4650	4600	4550	4500	4450	4400	4350
					(5.3)	(5.8)	15	24	30	34	38	41	44	46	48	50	53	53	55	56	57	58	60	61	61	62
7.0							4600	4100	3950	3950	3950	3950	3950	3950	3950	3950	3900	3950	3950	4000	4000	3950	3900	3850	3850	3800
							(6.3)	(6.8)	14	23	28	33	36	39	42	44	48	48	50	52	53	54	56	57	58	59
8.0									3700	3400	3250	3250	3250	3250	3250	3250	3250	3250	3300	3350	3350	3400	3450	3400	3350	3350
									(7.3)	(7.8)	14	22	27	31	35	38	42	43	45	47	48	50	51	53	54	55
9.0											3100	2800	2700	2700	2700	2700	2700	2700	2750	2800	2850	2850	2900	2950	2950	2950
											(8.3)	(8.8)	13	21	26	30	35	36	39	41	43	45	47	48	50	51
10													2550	2350	2300	2300	2300	2300	2350	2400	2400	2450	2450	2500	2550	2550
													(9.3)	(9.8)	12	20	28	29	32	35	38	40	42	44	45	47
11															2150	2000	1950	1950	2000	2050	2050	2100	2100	2150	2200	2200
															(10.3)	(10.8)	17	19	24	28	31	34	37	39	41	42
12																	1750	1700	1700	1750	1750	1800	1850	1850	1900	1900
																	(11.6)	(11.8)	12	19	23	27	30	33	36	37
13																			1600	1500	1500	1550	1600	1600	1650	1650
																			(12.3)	(12.8)	11	18	23	27	30	32
14																					1450	1350	1350	1400	1400	1450
																					(13.3)	(13.8)	11	18	22	25
15																							1300	1250	1250	1250
																							(14.3)	(14.8)	11	16
15.71																									1150	1100
																									(15.3)	(15.7)

NOTE : WEIGHT OF HOOKS, BLOCKS & OTHER LOAD HANDLING DEVICES SHALL BE ADDED TO THE WEIGHT OF THE LOAD

MAC-25 RHINO HOOK LOAD CHART - 10 DEG

LMI DUTY **102**

COUNTERWEIGHT ON FRONT OF CRANE - SPRING LOCKOUTS ENGAGED

15000 S.W.L. IN KILOGRAMS FOR SLEW ANGLES OF 10 DEGREES OR LESS EITHER SIDE OF STRAIGHT AHEAD (INDICATED BY GREEN LED ON DASH).
10000 BOOM ANGLE - UNDEFLECTED (REF.)

NOTE: VALUES IN BRACKETS () ARE ACTUAL RADIUS AT ZERO DEG. BOOM ANGLE.

S.W.L. ARE BASED ON 66.7% STABILITY & STRENGTH

- S.W.L. ABOVE BOLD RED LINE ARE STRUCTURAL

S.W.L. ARE BASED ON FIRM LEVEL GROUND (1% SLOPE (0.6 DEG) AS PER AS1418.5)

WITH TYRES INFLATED AS PER NOTES

LIFT & CARRY - THE S.W.L. SHALL BE CARRIED WITH THE MINIMUM BOOM LENGTH & AS

CLOSE TO THE GROUND AS POSSIBLE AT SPEEDS NOT IN EXCESS OF 0.4 M/SEC (1.44 KM/HR)

Radius in Metres	BOOM PIVOT TO HOOK CENTRE - THIRD BOOM RETRACTED (metres)														THIRD BOOM EXTENDING (metres)													
	6.45	7.00	7.50	8.00	8.50	9.00	9.50	10.00	10.50	11.00	11.50	12.00	12.50	13.00	13.50	14.00	14.65	15.00	15.50	16.00	16.50	17.00	17.50	18.00	18.50	18.75		
1.4	15000	15000	15000	15000	15000	15000	15000																					
	52	55	58	60	62	64	65																					
2.0	15000	15000	15000	15000	15000	15000	15000	15000	15000	15000																		
	44	49	52	55	57	59	61	63	64	65																		
2.5	15000	15000	15000	15000	15000	15000	15000	15000	15000	15000	15000	14200																
	37	43	47	50	53	56	58	59	61	63	64	65																
3.0	13000	12950	12900	12900	12850	12800	12800	12750	12700	12700	12700	12650	12300															
	29	36	41	45	49	52	54	56	58	60	61	62	64	65														
3.5	10900	10900	10900	10850	10800	10800	10750	10750	10700	10700	10700	10650	10650	10650	10600	10600												
	17	29	35	40	44	47	50	52	55	56	58	60	61	62	63	64												
4.0	10050	9350	9350	9300	9300	9250	9250	9250	9200	9200	9150	9150	9150	9150	9100	9100	9100	9100	9150									
	(3.7)	18	28	34	39	43	46	49	51	53	55	57	58	60	61	62	63	64	65									
5.0		8550	7500	7150	7150	7100	7100	7050	7050	7000	7000	7000	7000	7000	7000	7000	7000	7000	7050	7100	7100	7150	7200	7200				
		(4.3)	(4.8)	17	26	32	37	40	44	46	49	51	53	54	56	57	59	60	61	62	63	64	65	65				
6.0				6650	5900	5700	5700	5650	5650	5650	5600	5600	5600	5600	5600	5550	5600	5650	5650	5700	5750	5750	5800	5850	5850			
				(5.3)	(5.8)	16	24	30	35	38	42	44	47	49	51	52	54	55	57	58	59	60	61	62	63	63		
7.0						5300	4800	4650	4650	4600	4600	4600	4600	4600	4550	4550	4600	4650	4650	4700	4750	4750	4800	4800	4800			
						(6.3)	(6.8)	15	23	29	33	37	40	42	45	47	49	50	52	53	55	56	57	58	59	60		
8.0										4350	3950	3850	3850	3850	3850	3800	3800	3850	3850	3900	3950	3950	4000	4000	4050	4050		
										(7.3)	(7.8)	14	22	28	32	35	38	41	44	45	47	49	50	52	53	54		
9.0												3650	3350	3250	3250	3250	3250	3200	3200	3250	3300	3300	3350	3350	3400	3450	3450	3450
												(8.3)	(8.8)	13	21	27	31	34	38	39	42	44	46	47	49	50	51	52
10														3050	2800	2750	2750	2750	2750	2750	2800	2850	2850	2900	2950	2950	3000	3000
														(9.3)	(9.8)	13	20	26	31	33	36	38	40	42	44	46	47	48
11																2600	2400	2350	2350	2400	2400	2450	2500	2500	2550	2550	2600	2600
																(10.3)	(10.8)	12	21	25	29	32	35	37	39	41	43	44
12																		2250	2000	2050	2100	2100	2150	2200	2200	2250	2250	2250
																		(11.3)	(11.9)	12	19	24	28	31	34	36	38	39
13																				1950	1850	1850	1850	1900	1950	1950	2000	2000
																				(12.3)	(12.8)	12	18	23	27	30	33	34
14																						1750	1650	1650	1700	1700	1750	1750
																						(13.3)	(13.8)	11	18	23	26	28
15																								1600	1500	1500	1550	1550
																								(14.3)	(14.8)	11	17	20
16																										1450	1400	1350
																										(15.3)	(15.8)	(16.)

MAC-25 RHINO HOOK LOAD CHART - 40 DEG

LMI DUTY **102**

COUNTERWEIGHT ON FRONT OF CRANE - SPRING LOCKOUTS ENGAGED

Yellow Box S.W.L IN KILOGRAMS FOR SLEW ANGLES OF GREATER THAN 10 DEGREES UP TO 40 DEGREES EITHER SIDE OF STRAIGHT AHEAD (INDICATED BY RED LED ON DASH).
White Box BOOM ANGLE - UNDEFLECTED (REF.)

NOTE: VALUES IN BRACKETS () ARE ACTUAL RADIUS AT ZERO DEG. BOOM ANGLE.

S.W.L. ARE BASED ON 66.7% STABILITY & STRENGTH

- S.W.L. ABOVE BOLD RED LINE ARE STRUCTURAL

S.W.L. ARE BASED ON FIRM LEVEL GROUND (1% SLOPE (0.6 DEG) AS PER AS1418.5)

WITH TYRES INFLATED AS PER NOTES

LIFT & CARRY - THE S.W.L. SHALL BE CARRIED WITH THE MINIMUM BOOM LENGTH & AS

CLOSE TO THE GROUND AS POSSIBLE AT SPEEDS NOT IN EXCESS OF 0.4 M/SEC (1.44 KM/HR)

Radius in Metres	BOOM PIVOT TO HOOK CENTRE - THIRD BOOM RETRACTED (metres)														THIRD BOOM EXTENDING (metres)											
	6.45	7.00	7.50	8.00	8.50	9.00	9.50	10.00	10.50	11.00	11.50	12.00	12.50	13.00	13.50	14.00	14.65	15.00	15.50	16.00	16.50	17.00	17.50	18.00	18.50	18.75
1.4	15000	15000	15000	15000	15000	15000	14850																			
	52	55	58	60	62	64	65																			
2.0	15000	15000	15000	15000	15000	14650	13850	13100	12400	11850																
	44	49	52	55	57	59	61	63	64	65																
2.5	14200	14150	14100	14050	13550	12950	12400	11950	11500	11050	10550	10100														
	37	43	47	50	53	56	58	59	61	63	64	65														
3.0	11600	11550	11550	11500	11450	11100	10650	10250	9900	9600	9300	9050	8700													
	29	36	41	45	49	52	54	56	58	60	61	62	64	65												
3.5	9750	9700	9700	9650	9650	9600	9600	9550	9250	8950	8650	8400	8150	7950	7700	7500										
	17	29	35	40	44	47	50	52	55	56	58	60	61	62	63	64										
4.0	8950	8300	8300	8300	8250	8250	8200	8200	8150	8100	7850	7650	7400	7200	7000	6850	6650	6550	6450							
	(3.7)	18	28	34	39	43	46	49	51	53	55	57	58	60	61	62	63	64	65							
5.0		7600	6650	6300	6300	6300	6300	6250	6250	6200	6200	6200	6050	5900	5750	5550	5500	5450	5350	5300	5250	5150	5100			
		(4.3)	(4.8)	17	26	32	37	40	44	46	49	51	53	54	56	57	59	60	61	62	63	64	65	65		
6.0				5850	5200	5000	5000	5000	4950	4950	4950	4950	4900	4900	4900	4900	4750	4700	4650	4600	4550	4500	4450	4400	4350	4350
				(5.3)	(5.8)	16	24	30	35	38	42	44	47	49	51	52	54	55	57	58	59	60	61	62	63	63
7.0						4650	4200	4050	4050	4050	4000	4000	4000	4000	4000	4000	3950	4000	4050	4000	3950	3900	3900	3850	3800	3800
						(6.3)	(6.8)	15	23	29	33	37	40	42	45	47	49	50	52	53	55	56	57	58	59	60
8.0								3800	3450	3350	3350	3300	3300	3300	3300	3300	3300	3300	3350	3400	3450	3400	3400	3350	3350	3350
								(7.3)	(7.8)	14	22	28	32	35	38	41	44	45	47	49	50	52	53	54	55	56
9.0										3150	2850	2750	2750	2750	2750	2750	2750	2800	2800	2850	2900	2900	2950	2950	3000	2950
										(8.3)	(8.8)	13	21	27	31	34	38	39	42	44	46	47	49	50	51	52
10												2600	2400	2350	2350	2350	2300	2350	2400	2400	2450	2500	2500	2550	2550	2550
												(9.3)	(9.8)	13	20	26	31	33	36	38	40	42	44	46	47	48
11														2200	2000	1950	1950	2000	2050	2050	2100	2150	2150	2200	2200	2200
														(10.3)	(10.8)	12	21	25	29	32	35	37	39	41	43	44
12																1850	1650	1700	1750	1750	1800	1850	1850	1900	1900	1950
															(11.3)	(11.9)	12	19	24	28	31	34	36	38	39	
13																		1600	1500	1500	1550	1600	1600	1650	1650	1700
																	(12.3)	(12.8)	12	18	23	27	30	33	34	
14																				1450	1350	1350	1400	1400	1450	1450
																			(13.3)	(13.8)	11	18	23	26	28	
15																						1300	1250	1250	1250	1250
																					(14.3)	(14.8)	11	17	20	
16																								1150	1100	1100
																							(15.3)	(15.8)	(16.)	

NOTE: WEIGHT OF HOOKS, BLOCKS & OTHER LOAD HANDLING DEVICES SHALL BE ADDED TO THE WEIGHT OF THE LOAD

MAC-25 OFFSET HEAD BOTTOM POSITION LOAD CHART - 10 DEG

LMI DUTY **103**

COUNTERWEIGHT ON FRONT OF CRANE - SPRING LOCKOUTS ENGAGED



S.W.L. IN KILOGRAMS FOR SLEW ANGLES OF 10 DEGREES OR LESS EITHER SIDE OF STRAIGHT AHEAD (INDICATED BY GREEN LED ON DASH).



BOOM ANGLE - UNDEFLECTED (REF.)

NOTE: VALUES IN BRACKETS () ARE ACTUAL RADIUS AT ZERO DEG. BOOM ANGLE.

S.W.L. ARE BASED ON 66.7% STABILITY & STRENGTH

- S.W.L. ABOVE BOLD RED LINE ARE STRUCTURAL

S.W.L. ARE BASED ON FIRM LEVEL GROUND (1% SLOPE (0.6 DEG) AS PER AS1418.5)

WITH TYRES INFLATED AS PER NOTES

LIFT & CARRY - THE S.W.L. SHALL BE CARRIED WITH THE MINIMUM BOOM LENGTH & AS

CLOSE TO THE GROUND AS POSSIBLE AT SPEEDS NOT IN EXCESS OF 0.4 M/SEC (1.44 KM/HR)

Radius in Metres	BOOM PIVOT TO EDGE OF SHEAVE - THIRD BOOM RETRACTED (metres)															THIRD BOOM EXTENDING (metres)											
	6.86	7.00	7.50	8.00	8.50	9.00	9.50	10.00	10.50	11.00	11.50	12.00	12.50	13.00	13.50	14.00	14.50	15.06	15.50	16.00	16.50	17.00	17.50	18.00	18.50	19.16	
1.4	8400	8400	8400	8400	8400	8400																					
	55	56	59	61	63	65																					
2.0	8400	8400	8400	8400	8400	8400	8400	8400	8400																		
	49	50	53	56	58	60	62	64	65																		
2.5	8400	8400	8400	8400	8400	8400	8400	8400	8400	8400	8400																
	43	44	48	51	54	56	58	60	62	63	65																
3.0	8400	8400	8400	8400	8400	8400	8400	8400	8400	8400	8400	8400	8400														
	36	38	43	46	50	52	55	57	59	60	62	63	64	65													
3.5	8400	8400	8400	8400	8400	8400	8400	8400	8400	8400	8400	8400	8400	8400	8400												
	27	30	36	41	45	48	51	53	55	57	59	60	62	63	64	65											
4.0	8400	8400	8400	8400	8400	8400	8400	8400	8400	8400	8400	8400	8400	8400	8400	8400	8400										
	(4.2)	19	29	35	40	44	47	50	52	54	56	58	59	60	62	63	64	65									
5.0	8400	7650	7300	7300	7250	7250	7200	7200	7200	7150	7150	7150	7100	7100	7100	7100	7050	7100	7150	7200	7200	7250					
	(4.3)	(4.8)	18	27	33	38	41	44	47	49	52	53	55	57	58	59	61	61	62	63	64	65					
6.0			6750	6050	5800	5800	5800	5750	5750	5750	5700	5700	5700	5700	5650	5650	5650	5700	5700	5750	5800	5800	5850	5850	5850		
			(5.3)	(5.8)	16	25	31	36	39	42	45	47	49	51	53	54	56	57	58	59	60	61	62	63	64		
7.0					5400	4900	4750	4750	4700	4700	4700	4700	4700	4650	4650	4650	4650	4650	4700	4750	4750	4800	4800	4850	4900		
					(6.3)	(6.8)	16	24	30	34	37	40	43	45	47	49	51	52	54	55	56	57	59	59	61		
8.0							4450	4050	3950	3950	3950	3900	3900	3900	3900	3900	3850	3900	3950	3950	4000	4050	4050	4100	4100		
							(7.3)	(7.8)	15	23	28	33	36	39	41	44	46	48	49	51	52	53	55	56	57		
9.0									3700	3400	3300	3300	3300	3300	3300	3300	3300	3300	3350	3400	3400	3450	3450	3500	3500		
									(8.3)	(8.8)	14	22	27	31	35	37	40	42	44	46	48	49	51	52	53		
10											3150	2900	2800	2800	2800	2800	2800	2850	2850	2900	2950	2950	3000	3000	3050		
											(9.3)	(9.8)	14	21	26	30	34	36	39	41	43	45	46	48	50		
11													2650	2450	2400	2400	2400	2450	2450	2500	2550	2550	2600	2600	2650		
													(10.3)	(10.8)	13	20	26	29	32	35	37	40	42	43	45		
12			NOTE : WEIGHT OF HOOKS, BLOCKS & OTHER LOAD HANDLING DEVICES SHALL BE ADDED TO THE WEIGHT OF THE LOAD														2300	2100	2050	2100	2150	2200	2200	2250	2250	2300	2300
															(11.3)	(11.8)	14	20	24	28	31	34	36	39	41		
13																	1950	1850	1850	1900	1900	1950	2000	2000	2050		
																(12.4)	(12.8)	12	19	24	27	30	33	36			
14																			1750	1700	1700	1700	1750	1750	1800		
																		(13.3)	(13.8)	12	18	23	27	30			
15																				1600	1500	1500	1550	1600			
																			(14.3)	(14.8)	12	18	24				
16.4																						1450	1400	1300			
																						(15.3)	(15.8)	(16.4)			

MAC-25 OFFSET HEAD BOTTOM POSITION LOAD CHART - 40 DEG

LMI DUTY **103**

COUNTERWEIGHT ON FRONT OF CRANE - SPRING LOCKOUTS ENGAGED

- S.W.L IN KILOGRAMS FOR SLEW ANGLES OF GREATER THAN 10 DEGREES UP TO 40 DEGREES EITHER SIDE OF STRAIGHT AHEAD (INDICATED BY RED LED ON DASH).
- BOOM ANGLE - UNDEFLECTED (REF.)

NOTE : VALUES IN BRACKETS () ARE ACTUAL RADIUS AT ZERO DEG. BOOM ANGLE.

S.W.L. ARE BASED ON 66.7% STABILITY & STRENGTH

- S.W.L. ABOVE BOLD RED LINE ARE STRUCTURAL

S.W.L. ARE BASED ON FIRM LEVEL GROUND (1% SLOPE (0.6 DEG) AS PER AS1418.5)

WITH TYRES INFLATED AS PER NOTES

LIFT & CARRY - THE S.W.L. SHALL BE CARRIED WITH THE MINIMUM BOOM LENGTH & AS

CLOSE TO THE GROUND AS POSSIBLE AT SPEEDS NOT IN EXCESS OF 0.4 M/SEC (1.44 KM/HR)

Radius in Metres	BOOM PIVOT TO EDGE OF SHEAVE - THIRD BOOM RETRACTED (metres)															THIRD BOOM EXTENDING (metres)										
	6.86	7.00	7.50	8.00	8.50	9.00	9.50	10.00	10.50	11.00	11.50	12.00	12.50	13.00	13.50	14.00	14.50	15.06	15.50	16.00	16.50	17.00	17.50	18.00	18.50	19.16
1.4	8400	8400	8400	8400	8400	8400																				
	55	56	59	61	63	65																				
2.0	8400	8400	8400	8400	8400	8400	8400	8400	8400																	
	49	50	53	56	58	60	62	64	65																	
2.5	8400	8400	8400	8400	8400	8400	8400	8400	8400	8400	8400															
	43	44	48	51	54	56	58	60	62	63	65															
3.0	8400	8400	8400	8400	8400	8400	8400	8400	8400	8400	8400	8400	8400													
	36	38	43	46	50	52	55	57	59	60	62	63	64	65												
3.5	8400	8400	8400	8400	8400	8400	8400	8400	8400	8400	8400	8400	8250	8050	7850	7600										
	27	30	36	41	45	48	51	53	55	57	59	60	62	63	64	65										
4.0	8050	8400	8400	8400	8400	8400	8350	8350	8300	8250	8000	7750	7500	7300	7100	6950	6750	6600								
	(4.2)	19	29	35	40	44	47	50	52	54	56	58	59	60	62	63	64	65								
5.0	7750	6750	6450	6450	6450	6400	6400	6350	6350	6300	6300	6150	6000	5850	5700	5550	5500	5400	5350	5250	5200					
	(4.3)	(4.8)	18	27	33	38	41	44	47	49	52	53	55	57	58	59	61	61	62	63	64	65				
6.0				5950	5300	5100	5100	5100	5050	5050	5050	5050	5000	5000	5000	4850	4750	4700	4650	4600	4550	4500	4450	4400	4300	
				(5.3)	(5.8)	16	25	31	36	39	42	45	47	49	51	53	54	56	57	58	59	60	61	62	63	64
7.0						4750	4300	4150	4150	4150	4100	4100	4100	4100	4050	4050	4050	4050	4050	4050	4000	3950	3900	3850	3850	3800
						(6.3)	(6.8)	16	24	30	34	37	40	43	45	47	49	51	52	54	55	56	57	59	61	
8.0								3900	3500	3400	3400	3400	3400	3400	3400	3350	3350	3350	3400	3400	3450	3450	3450	3400	3400	3350
								(7.3)	(7.8)	15	23	28	33	36	39	41	44	46	48	49	51	52	53	55	56	57
9.0										3200	2950	2850	2850	2850	2850	2850	2800	2800	2850	2900	2900	2950	2950	3000	3000	2950
										(8.3)	(8.8)	14	22	27	31	35	37	40	42	44	46	48	49	51	52	53
10												2700	2450	2400	2400	2400	2400	2400	2400	2450	2500	2500	2550	2550	2600	2600
												(9.3)	(9.8)	14	21	26	30	34	36	39	41	43	45	46	48	50
11														2250	2100	2050	2050	2050	2050	2100	2150	2150	2200	2200	2250	2250
														(10.3)	(10.8)	13	20	26	29	32	35	37	40	42	43	45
12																1900	1750	1700	1750	1800	1850	1850	1900	1900	1950	1950
																(11.3)	(11.8)	14	20	24	28	31	34	36	39	41
13																	1600	1550	1550	1550	1600	1650	1650	1700	1700	
																	(12.4)	(12.8)	12	19	24	27	30	33	36	
14																			1450	1350	1400	1400	1450	1450	1500	
																			(13.3)	(13.8)	12	18	23	27	30	
15																					1300	1250	1250	1250	1300	
																					(14.3)	(14.8)	12	18	24	
16.4																							1200	1100	1050	
																							(15.3)	(15.8)	(16.4)	

MAC-25 OFFSET HEAD TOP POSITION LOAD CHART - 10 DEG

LMI DUTY **104**

COUNTERWEIGHT ON FRONT OF CRANE - SPRING LOCKOUTS ENGAGED

Yellow Box S.W.L IN KILOGRAMS FOR SLEW ANGLES OF 10 DEGREES OR LESS EITHER SIDE OF STRAIGHT AHEAD (INDICATED BY GREEN LED ON DASH).
White Box BOOM ANGLE - UNDEFLECTED (REF.)

S.W.L. ARE BASED ON 66.7% STABILITY & STRENGTH

- S.W.L. ABOVE BOLD RED LINE ARE STRUCTURAL

S.W.L. ARE BASED ON FIRM LEVEL GROUND (1% SLOPE (0.6 DEG) AS PER AS1418.5) WITH TYRES INFLATED AS PER NOTES

LIFT & CARRY - THE S.W.L. SHALL BE CARRIED WITH THE MINIMUM BOOM LENGTH & AS CLOSE TO THE GROUND AS POSSIBLE AT SPEEDS NOT IN EXCESS OF 0.4 M/SEC (1.44 KM/HR)

NOTE : VALUES IN BRACKETS () ARE ACTUAL RADIUS AT ZERO DEG. BOOM ANGLE.

Radius in Metres	BOOM PIVOT TO EDGE OF SHEAVE - THIRD BOOM RETRACTED (metres)															THIRD BOOM EXTENDING (metres)											
	6.82	7.00	7.50	8.00	8.50	9.00	9.50	10.00	10.50	11.00	11.50	12.00	12.50	13.00	13.50	14.00	14.50	15.02	15.50	16.00	16.50	17.00	17.50	18.00	18.50	19.12	
1.4	8400	8400	8400	8400	8400	8400	8400																				
	52	53	56	58	60	62	64																				
2.0	8400	8400	8400	8400	8400	8400	8400	8400	8400	8400																	
	45	47	50	53	56	58	60	61	63	64																	
2.5	8400	8400	8400	8400	8400	8400	8400	8400	8400	8400	8400	8400															
	39	41	45	49	52	54	56	58	60	61	63	64															
3.0	8400	8400	8400	8400	8400	8400	8400	8400	8400	8400	8400	8400	8400	8400													
	32	34	40	44	47	50	53	55	57	58	60	61	63	64	65												
3.5	8400	8400	8400	8400	8400	8400	8400	8400	8400	8400	8400	8400	8400	8400	8400	8400											
	24	27	33	38	42	46	49	51	53	55	57	59	60	61	62	63	64										
4.0	8400	8400	8400	8400	8400	8400	8400	8400	8400	8400	8400	8400	8400	8400	8400	8400	8400	8400	8400								
	(4.1)	16	26	32	37	41	45	47	50	52	54	56	57	59	60	61	62	63	64								
5.0	8400	7600	7250	7200	7200	7150	7150	7100	7100	7050	7050	7050	7050	7000	7000	7000	6950	7000	7050	7100	7100	7150	7200				
	(4.3)	(4.8)	15	24	30	35	39	42	45	48	50	52	53	55	56	58	59	60	61	62	63	64	65				
6.0				6750	6000	5750	5750	5750	5700	5700	5650	5650	5650	5650	5600	5600	5600	5550	5600	5650	5700	5700	5750	5750	5800	5850	
				(5.3)	(5.8)	14	23	29	34	37	40	43	46	48	50	51	53	54	56	57	58	59	60	61	62	63	
7.0						5400	4900	4700	4700	4700	4650	4650	4650	4600	4600	4600	4600	4550	4600	4650	4700	4700	4750	4750	4800	4800	
						(6.3)	(6.8)	14	22	28	32	36	39	41	44	46	48	50	51	53	54	55	56	57	58	59	
8.0								4450	4050	3900	3900	3900	3900	3850	3850	3850	3850	3800	3850	3900	3900	3950	4000	4000	4050	4050	
								(7.3)	(7.8)	13	21	27	31	34	37	40	42	44	46	48	49	51	52	53	55	56	
9.0										3700	3400	3300	3300	3250	3250	3250	3250	3250	3250	3300	3350	3350	3400	3400	3450	3450	
										(8.3)	(8.8)	12	20	25	30	33	36	39	41	43	45	46	48	49	51	52	
10												3100	2900	2800	2800	2800	2750	2750	2800	2850	2850	2900	2900	2950	2950	3000	
												(9.3)	(9.8)	12	19	25	29	32	35	37	40	42	43	45	47	48	
11														2650	2450	2400	2400	2400	2400	2450	2500	2500	2550	2550	2600	2600	
														(10.3)	(10.8)	12	19	24	28	31	34	36	38	40	42	44	
12																2300	2100	2050	2100	2100	2150	2200	2200	2250	2250	2300	
																(11.3)	(11.8)	12	18	23	27	30	33	35	37	40	
13																	1950	1850	1850	1900	1900	1950	1950	2000	2000		
																(12.3)	(12.8)	11	18	22	26	29	32	35	35		
14																				1750	1650	1650	1700	1700	1750	1800	
																				(13.3)	(13.8)	11	17	22	25	29	
15																						1600	1500	1500	1550	1550	
																						(14.3)	(14.8)	10	17	22	
16.45																								1450	1400	1300	
																								(15.3)	(15.8)	(16.5)	

MAC-25 OFFSET HEAD TOP POSITION LOAD CHART - 40 DEG

LMI DUTY **104**

COUNTERWEIGHT ON FRONT OF CRANE - SPRING LOCKOUTS ENGAGED



S.W.L IN KILOGRAMS FOR SLEW ANGLES OF GREATER THAN 10 DEGREES UP TO 40 DEGREES EITHER SIDE OF STRAIGHT AHEAD (INDICATED BY RED LED ON DASH).



BOOM ANGLE - UNDEFLECTED (REF.)

NOTE : VALUES IN BRACKETS () ARE ACTUAL RADIUS AT ZERO DEG. BOOM ANGLE.

S.W.L. ARE BASED ON 66.7% STABILITY & STRENGTH

- S.W.L. ABOVE BOLD RED LINE ARE STRUCTURAL

S.W.L. ARE BASED ON FIRM LEVEL GROUND (1% SLOPE (0.6 DEG) AS PER AS1418.5) WITH TYRES INFLATED AS PER NOTES

LIFT & CARRY - THE S.W.L. SHALL BE CARRIED WITH THE MINIMUM BOOM LENGTH & AS CLOSE TO THE GROUND AS POSSIBLE AT SPEEDS NOT IN EXCESS OF 0.4 M/SEC (1.44 KM/HR)

Radius in Metres	BOOM PIVOT TO EDGE OF SHEAVE - THIRD BOOM RETRACTED (metres)															THIRD BOOM EXTENDING (metres)										
	6.82	7.00	7.50	8.00	8.50	9.00	9.50	10.00	10.50	11.00	11.50	12.00	12.50	13.00	13.50	14.00	14.50	15.02	15.50	16.00	16.50	17.00	17.50	18.00	18.50	19.12
1.4	8400	8400	8400	8400	8400	8400	8400																			
	52	53	56	58	60	62	64																			
2.0	8400	8400	8400	8400	8400	8400	8400	8400	8400	8400																
	45	47	50	53	56	58	60	61	63	64																
2.5	8400	8400	8400	8400	8400	8400	8400	8400	8400	8400	8400															
	39	41	45	49	52	54	56	58	60	61	63	64														
3.0	8400	8400	8400	8400	8400	8400	8400	8400	8400	8400	8400	8400	8400	8400												
	32	34	40	44	47	50	53	55	57	58	60	61	63	64	65											
3.5	8400	8400	8400	8400	8400	8400	8400	8400	8400	8400	8400	8400	8200	7950	7750	7550	7300									
	24	27	33	38	42	46	49	51	53	55	57	59	60	61	62	63	64									
4.0	8150	8400	8400	8350	8350	8300	8250	8250	8200	8150	7900	7650	7450	7250	7050	6850	6700	6550	6450							
	(4.1)	16	26	32	37	41	45	47	50	52	54	56	57	59	60	61	62	63	64							
5.0		7750	6750	6400	6400	6350	6350	6300	6300	6250	6250	6250	6200	6100	5900	5750	5650	5500	5400	5350	5300	5200	5150	5100		
		(4.3)	(4.8)	15	24	30	35	39	42	45	48	50	52	53	55	56	58	59	60	61	62	63	64	65		
6.0				5950	5300	5050	5050	5050	5000	5000	5000	4950	4950	4950	4900	4900	4800	4700	4650	4600	4550	4500	4450	4400	4350	4300
				(5.3)	(5.8)	14	23	29	34	37	40	43	46	48	50	51	53	54	56	57	58	59	60	61	62	63
7.0					4750	4250	4100	4100	4100	4050	4050	4050	4050	4000	4000	4000	4000	4000	4000	4000	3950	3900	3850	3850	3800	3750
					(6.3)	(6.8)	14	22	28	32	36	39	41	44	46	48	50	51	53	54	55	56	57	58	59	
8.0								3850	3500	3400	3400	3350	3350	3350	3350	3300	3300	3300	3350	3350	3400	3450	3400	3350	3350	3300
								(7.3)	(7.8)	13	21	27	31	34	37	40	42	44	46	48	49	51	52	53	55	56
9.0										3200	2900	2800	2800	2800	2800	2800	2750	2800	2850	2850	2900	2950	2950	2950	2950	2950
										(8.3)	(8.8)	12	20	25	30	33	36	39	41	43	45	46	48	49	51	52
10											2700	2450	2400	2350	2350	2350	2350	2400	2400	2450	2500	2500	2550	2550	2600	
										(9.3)	(9.8)	12	19	25	29	32	35	37	40	42	43	45	47	48		
11														2250	2050	2000	2000	2050	2050	2100	2150	2150	2200	2200	2250	
														(10.3)	(10.8)	12	19	24	28	31	34	36	38	40	42	44
12																1900	1750	1700	1750	1750	1800	1850	1850	1900	1900	1950
															(11.3)	(11.8)	12	18	23	27	30	33	35	37	40	
13																	1600	1550	1500	1550	1600	1600	1650	1650	1700	
																(12.3)	(12.8)	11	18	22	26	29	32	35		
14																			1450	1350	1350	1400	1400	1450	1500	
																		(13.3)	(13.8)	11	17	22	25	29		
15																					1300	1250	1250	1250	1300	
																				(14.3)	(14.8)	10	17	22		
16.45																							1200	1100	1050	
																							(15.3)	(15.8)	(16.5)	

MAC-25 3m FLYJIB TOP POSITION AT 0 DEG OFFSET LOAD CHART

COUNTERWEIGHT ON FRONT OF CRANE - SPRING LOCKOUTS ENGAGED

LMI DUTY

105

PIVOT TO FLY JIB MAX LENGTH 21.4m	
MAX RADIUS	SWL
6.10	1500
	65
7.76	1500
	60
9.34	1200
	55
10.83	1200
	50
12.22	970
	45
13.49	970
	40
14.65	850
	35
15.67	850
	30
16.55	770
	25
17.29	770
	20
17.88	750
	15
18.31	750
	10
18.58	750
	5
18.69	750
	0



S.W.L IN KILOGRAMS FOR SLEW ANGLES UP TO 40

DEGREES EITHER SIDE OF STRAIGHT AHEAD (INDICATED BY RED LED ON DASH).



BOOM ANGLE - UNDEFLECTED (REF.)

NOTE : VALUES IN BRACKETS () ARE ACTUAL RADIUS AT ZERO DEG. BOOM ANGLE.

SWL IS AT THIS RADIUS

SPRING LOCKOUTS ARE TO BE ENGAGED FOR ALL LIFTING OPERATIONS

S.W.L. ARE BASED ON 66.6% STABILITY & STRENGTH

ALL FLYJIB S.W.L.'S ARE STRUCTURAL

S.W.L. ARE BASED ON FIRM LEVEL GROUND (1% SLOPE (0.6 DEG) AS PER AS1418.5)

WITH TYRES INFLATED AS PER NOTES

LIFT & CARRY - THE S.W.L. SHALL BE CARRIED WITH THE MINIMUM BOOM LENGTH & AS

CLOSE TO THE GROUND AS POSSIBLE AT SPEEDS NOT IN EXCESS OF 0.4 M/SEC (1.44 KM/HR)

FLYJIB S.W.L.'S AND RADII ARE BASED ON FULLY EXTENDED BOOM.

FOR OPERATION THE BOOM PART OR FULLY RETRACTED

THE SWL WILL BE BASED ON THE BOOM ANGLE, NOT THE ACTUAL RADIUS.

NOTE : WEIGHT OF HOOKS, BLOCKS & OTHER
LOAD HANDLING DEVICES SHALL BE ADDED
TO THE WEIGHT OF THE LOAD

MAC-25 3m FLYJIB TOP POSITION AT 12.5 DEG OFFSET LOAD CHART

COUNTERWEIGHT ON FRONT OF CRANE - SPRING LOCKOUTS ENGAGED

LMI DUTY

106

PIVOT TO FLY JIB MAX LENGTH 21.4m	
MAX RADIUS	SWL
6.60	1300
	65
8.23	1300
	60
9.78	1120
	55
11.24	1120
	50
12.59	920
	45
13.83	920
	40
14.94	820
	35
15.92	820
	30
16.76	770
	25
17.45	770
	20
17.99	750
	15
18.37	750
	10
18.59	750
	5
18.65	750
	0



S.W.L IN KILOGRAMS FOR SLEW ANGLES UP TO 40 DEGREES EITHER SIDE OF STRAIGHT AHEAD (INDICATED BY RED LED ON DASH).



BOOM ANGLE - UNDEFLECTED (REF.)

NOTE : VALUES IN BRACKETS () ARE ACTUAL RADIUS AT ZERO DEG. BOOM ANGLE.
SWL IS AT THIS RADIUS

SPRING LOCKOUTS ARE TO BE ENGAGED FOR ALL LIFTING OPERATIONS

S.W.L. ARE BASED ON 66.6% STABILITY & STRENGTH

ALL FLYJIB S.W.L.'S ARE STRUCTURAL

S.W.L. ARE BASED ON FIRM LEVEL GROUND (1% SLOPE (0.6 DEG) AS PER AS1418.5)

WITH TYRES INFLATED AS PER NOTES

LIFT & CARRY - THE S.W.L. SHALL BE CARRIED WITH THE MINIMUM BOOM LENGTH & AS

CLOSE TO THE GROUND AS POSSIBLE AT SPEEDS NOT IN EXCESS OF 0.4 M/SEC (1.44 KM/HR)

FLYJIB S.W.L.'S AND RADII ARE BASED ON FULLY EXTENDED BOOM.



FOR OPERATION WITH THE BOOM PART OR FULLY RETRACTED

THE SWL WILL BE BASED ON THE BOOM ANGLE, NOT THE ACTUAL RADIUS.

**NOTE : WEIGHT OF HOOKS, BLOCKS & OTHER
LOAD HANDLING DEVICES SHALL BE ADDED
TO THE WEIGHT OF THE LOAD**

MAC-25 4m FLYJIB TOP POSITION AT 5 DEG OFFSET LOAD CHART
 COUNTERWEIGHT ON FRONT OF CRANE - SPRING LOCKOUTS ENGAGED

PIVOT TO FLY JIB MAX LENGTH 22.48m	
MAX RADIUS	SWL
6.85	700
	65
8.58	600
	60
10.23	600
	55
11.77	600
	50
13.21	600
	45
14.53	500
	40
15.72	500
	35
16.77	500
	30
17.67	500
	25
18.42	500
	20
19.00	500
	15
19.43	500
	10
19.68	500
	5
19.77	500
	0

 S.W.L IN KILOGRAMS FOR SLEW ANGLES UP TO 40 DEGREES EITHER SIDE OF STRAIGHT AHEAD (INDICATED BY RED LED ON DASH).
 BOOM ANGLE - UNDEFLECTED (REF.)
 NOTE : VALUES IN BRACKETS () ARE ACTUAL RADIUS AT ZERO DEG. BOOM ANGLE.
 SWL IS AT THIS RADIUS

SPRING LOCKOUTS ARE TO BE ENGAGED FOR ALL LIFTING OPERATIONS

S.W.L. ARE BASED ON 66.6% STABILITY & STRENGTH
 ALL FLYJIB S.W.L.'S ARE STRUCTURAL
 S.W.L. ARE BASED ON FIRM LEVEL GROUND (1% SLOPE (0.6 DEG) AS PER AS1418.5)
 WITH TYRES INFLATED AS PER NOTES
 LIFT & CARRY - THE S.W.L. SHALL BE CARRIED WITH THE MINIMUM BOOM LENGTH & AS CLOSE TO THE GROUND AS POSSIBLE AT SPEEDS NOT IN EXCESS OF 0.4 M/SEC (1.44 KM/HR)

FLYJIB S.W.L.'S AND RADII ARE BASED ON FULLY EXTENDED BOOM.
 FOR OPERATION THE BOOM PART OR FULLY RETRACTED
 THE SWL WILL BE BASED ON THE BOOM ANGLE, NOT THE ACTUAL RADIUS.

NOTE : WEIGHT OF HOOKS, BLOCKS & OTHER LOAD HANDLING DEVICES SHALL BE ADDED TO THE WEIGHT OF THE LOAD

MAC-25 4m FLYJIB BOTTOM POSITION AT 17.5 DEG OFFSET LOAD CHART

COUNTERWEIGHT ON FRONT OF CRANE - SPRING LOCKOUTS ENGAGED

LMI DUTY

108

PIVOT TO FLY JIB MAX LENGTH 22.41m	
MAX RADIUS	SWL
7.82	600
	65
9.50	600
	60
11.09	600
	55
12.57	500
	50
13.94	500
	45
15.18	500
	40
16.29	500
	35
17.25	500
	30
18.07	500
	25
18.72	500
	20
19.22	500
	15
19.55	500
	10
19.70	500
	5
19.70	500
	0



S.W.L IN KILOGRAMS FOR SLEW ANGLES UP TO 40 DEGREES EITHER SIDE OF STRAIGHT AHEAD (INDICATED BY RED LED ON DASH).



BOOM ANGLE - UNDEFLECTED (REF.)

NOTE : VALUES IN BRACKETS () ARE ACTUAL RADIUS AT ZERO DEG. BOOM ANGLE. SWL IS AT THIS RADIUS

SPRING LOCKOUTS ARE TO BE ENGAGED FOR ALL LIFTING OPERATIONS

S.W.L. ARE BASED ON 66.6% STABILITY & STRENGTH

ALL FLYJIB S.W.L.'S ARE STRUCTURAL

S.W.L. ARE BASED ON FIRM LEVEL GROUND (1% SLOPE (0.6 DEG) AS PER AS1418.5)

WITH TYRES INFLATED AS PER NOTES

LIFT & CARRY - THE S.W.L. SHALL BE CARRIED WITH THE MINIMUM BOOM LENGTH & AS CLOSE TO THE GROUND AS POSSIBLE AT SPEEDS NOT IN EXCESS OF 0.4 M/SEC (1.44 KM/HR)

FLYJIB S.W.L.'S AND RADII ARE BASED ON FULLY EXTENDED BOOM.

FOR OPERATION WITH THE BOOM PART OR FULLY RETRACTED

THE SWL WILL BE BASED ON THE BOOM ANGLE, NOT THE ACTUAL RADIUS.

NOTE : WEIGHT OF HOOKS, BLOCKS & OTHER LOAD HANDLING DEVICES SHALL BE ADDED TO THE WEIGHT OF THE LOAD

MAC-25 MAN BASKET LOAD CHART

COUNTERWEIGHT ON FRONT OF CRANE - SPRING LOCKOUTS ENGAGED

LMI DUTY

109

**MAXIMUM MANBASKET SWL: 275 KG (SEE NOTE BELOW)
BASKET WEIGHT: 225 KG**

*Read and understand warning notes before
operating crane*

**NOTE: THE TOTAL WEIGHT OF THE MANBASKET PLUS
MEN AND EQUIPMENT IS NOT TO EXCEED 1/3 OF
THE SAFE WORKING LOAD AS READ ON LOAD
CHART (FALL BLOCK LOAD CHART - DUTY 101)
FOR THE BOOM LENGTH AND RADIUS BEING USED.**

MAC-25 BUTT LUG - 10 DEG. ART.

COUNTERWEIGHT ON FRONT OF CRANE - SPRING LOCKOUTS ENGAGED



S.W.L IN KILOGRAMS FOR SLEW ANGLES OF 10 DEGREES OR LESS EITHER SIDE OF STRAIGHT AHEAD (INDICATED BY GREEN LED ON DASH).



BOOM ANGLE - UNDEFLECTED (REF.)

NOTE : VALUES IN BRACKETS () ARE ACTUAL RADIUS AT ZERO DEG. BOOM ANGLE. SWL IS AT THIS RADIUS

MAC-25 BUTT LUG - 40 DEG. ART.

COUNTERWEIGHT ON FRONT OF CRANE - SPRING LOCKOUTS ENGAGED



S.W.L IN KILOGRAMS FOR SLEW ANGLES OF GREATER THAN 10 DEGREES UP TO 40 DEGREES EITHER SIDE OF STRAIGHT AHEAD (INDICATED BY RED LED ON DASH).



BOOM ANGLE - UNDEFLECTED (REF.)

NOTE : VALUES IN BRACKETS () ARE ACTUAL RADIUS AT ZERO DEG. BOOM ANGLE. SWL IS AT THIS RADIUS

S.W.L. ARE BASED ON 66.7% STABILITY & STRENGTH - S.W.L. ABOVE BOLD RED LINE ARE STRUCTURAL

S.W.L. ARE BASED ON FIRM, LEVEL GROUND (1% SLOPE (0.6 DEG) AS PER AS1418.5) WITH TYRES INFLATED AS PER NOTES

LIFT & CARRY - THE S.W.L. SHALL BE CARRIED WITH THE MINIMUM BOOM LENGTH & AS CLOSE TO THE GROUND AS POSSIBLE AT SPEEDS NOT IN EXCESS OF 0.4 M/SEC (1.44 KM/HR)

NOTE : WEIGHT OF HOOKS, BLOCKS & OTHER LOAD HANDLING DEVICES SHALL BE ADDED TO THE WEIGHT OF THE LOAD

Radius in Metres	Boom Length (metres)
1.4	4.81
	23550
1.5	32
	23100
1.6	30
	22700
1.7	27
	22300
1.8	24
	21400
1.9	21
	20150
2.1	18
	17950
	0

NOTE : WEIGHT OF HOOKS, BLOCKS & OTHER LOAD HANDLING DEVICES SHALL BE ADDED TO THE WEIGHT OF THE LOAD

Radius in Metres	Boom Length (metres)
1.4	4.81
	23550
1.5	32
	23100
1.6	30
	21700
1.7	27
	20300
1.8	24
	19100
1.9	21
	17950
2.1	18
	15950
	0

MAC25 LUG 1 LOAD CHART - 10 DEG. ART.

COUNTERWEIGHT ON FRONT OF CRANE - SPRING LOCKOUTS ENGAGED



S.W.L IN KILOGRAMS FOR SLEW ANGLES OF 10 DEGREES OR LESS EITHER SIDE OF STRAIGHT AHEAD (INDICATED BY GREEN LED ON DASH).



BOOM ANGLE - UNDEFLECTED (REF.)

NOTE: VALUES IN BRACKETS () ARE ACTUAL RADIUS AT ZERO DEG. BOOM ANGLE. SWL IS AT THIS RADIUS

MAC25 LUG 1 LOAD CHART - 40 DEG. ART.

COUNTERWEIGHT ON FRONT OF CRANE - SPRING LOCKOUTS ENGAGED



S.W.L IN KILOGRAMS FOR SLEW ANGLES OF GREATER THAN 10 DEGREES UP TO 40 DEGREES EITHER SIDE OF STRAIGHT AHEAD (INDICATED BY RED LED ON DASH).



BOOM ANGLE - UNDEFLECTED (REF.)

NOTE: VALUES IN BRACKETS () ARE ACTUAL RADIUS AT ZERO DEG. BOOM ANGLE. SWL IS AT THIS RADIUS

S.W.L. ARE BASED ON 66.7% STABILITY & STRENGTH - S.W.L. ABOVE BOLD RED LINE ARE STRUCTURAL

S.W.L. ARE BASED ON FIRM, LEVEL GROUND (1% SLOPE (0.6 DEG) AS PER AS1418.5) WITH TYRES INFLATED AS PER NOTES

LIFT & CARRY - THE S.W.L. SHALL BE CARRIED WITH THE MINIMUM BOOM LENGTH & AS CLOSE TO THE GROUND AS POSSIBLE AT SPEEDS NOT IN EXCESS OF 0.4 M/SEC (1.44 KM/HR)

NOTE : WEIGHT OF HOOKS, BLOCKS & OTHER LOAD HANDLING DEVICES SHALL BE ADDED TO THE WEIGHT OF THE LOAD

RADIUS IN METRES	BOOM PIVOT TO LUG 1, 1st EXTENSION, THIRD EXTENSION RETRACTED (metres)									
	5.36	5.50	6.00	6.50	7.00	7.50	8.00	8.50	9.00	9.46
1.4	24350	24300	24100	23950	23750	23600	23450	23250	23100	22950
	40	42	47	51	54	57	59	61	63	64
2	19500	19400	19100	18850	18600	18400	18200	18000	17900	17750
	29	31	38	44	48	51	54	56	59	60
2.5	15250	15200	14950	14700	14500	14300	14150	14000	13850	13750
	14	19	30	37	42	46	49	52	55	57
3	14200	13350	12100	11950	11750	11600	11450	11300	11200	11100
	(2.7)	(2.8)	18	29	35	41	45	48	51	53
3.5			10800	9950	9800	9650	9500	9400	9300	9200
			(3.3)	17	28	34	39	43	46	49
4				8900	8300	8150	8050	7950	7850	7750
				(3.8)	17	27	33	38	42	45
5					7500	6350	6000	5900	5800	5750
					(4.3)	(4.8)	16	25	31	36
6							5400	4650	4450	4400
							(5.3)	(5.8)	15	23
6.8									4000	3500
									(6.3)	(6.8)

RADIUS IN METRES	BOOM PIVOT TO LUG 1, 1st EXTENSION, THIRD EXTENSION RETRACTED (metres)									
	5.36	5.50	6.00	6.50	7.00	7.50	8.00	8.50	9.00	9.46
1.4	24350	24300	23450	21550	17850	16350	15100	14100	13200	12450
	40	42	47	51	54	57	59	61	63	64
2	17450	17350	17000	16750	16500	15650	14700	13850	13100	11300
	29	31	38	44	48	51	54	56	59	60
2.5	13600	13500	13250	13050	12800	12650	12500	12100	11400	10900
	14	19	30	37	42	46	49	52	55	57
3	12650	11850	10750	10550	10350	10200	10050	9900	9800	9550
	(2.7)	(2.8)	18	29	35	41	45	48	51	53
3.5			9500	8750	8600	8450	8300	8200	8100	8000
			(3.3)	17	28	34	39	43	46	49
4				7800	7250	7150	7000	6900	6800	6700
				(3.8)	17	27	33	38	42	45
5					6500	5500	5150	5050	5000	4900
					(4.3)	(4.8)	16	25	31	36
6							4650	3950	3750	3700
							(5.3)	(5.8)	15	23
6.8									3350	2900
									(6.3)	(6.8)

**THIS PAGE HAS BEEN
INTENTIONALLY LEFT BLANK**

MAC-25 LUG 2 LOAD CHART - 10 DEG. ART.

LMI DUTY

112

COUNTERWEIGHT ON FRONT OF CRANE - SPRING LOCKOUTS ENGAGED



S.W.L IN KILOGRAMS FOR SLEW ANGLES OF 10 DEGREES OR LESS EITHER SIDE OF STRAIGHT AHEAD (INDICATED BY GREEN LED ON DASH).



BOOM ANGLE - UNDEFLECTED (REF.)

S.W.L. ARE BASED ON 66.7% STABILITY & STRENGTH

- S.W.L. ABOVE BOLD RED LINE ARE STRUCTURAL

S.W.L. ARE BASED ON FIRM LEVEL GROUND (1% SLOPE (0.6 DEG

NOTE: VALUES IN BRACKETS () ARE ACTUAL RADIUS AT ZERO DEG. BOOM ANGLE.

AS PER AS1418.5) WITH TYRES INFLATED AS PER NOTES

ENSURE WINCH ROPE IS FULLY TENSIONED

LIFT & CARRY - THE S.W.L. SHALL BE CARRIED WITH THE MIN BOOM LENGTH & AS CLOSE TO THE GROUND AS POSSIBLE AT SPEEDS NOT IN EXCESS OF 0.4 M/SEC (1.44 KM/HR)

Radius in Metres	BOOM PIVOT TO LUG 2, 2nd EXTENSION, THIRD EXTENSION RETRACTED (metres)																	
	5.57	6.00	6.50	7.00	7.50	8.00	8.50	9.00	9.50	10.00	10.50	11.00	11.50	12.00	12.50	13.00	13.50	13.77
1.4	24550	24500	24450	24400	24350	24300	24200	24150	24100									
	42	46	50	54	57	59	61	63	64									
2	19650	19600	19600	19550	19550	19500	19500	19450	19450	19400	19400							
	32	38	43	47	51	54	56	58	60	62	63	64						
2.5	15400	15400	15350	15350	15350	15300	15300	15300	15250	15250	15250	15200	15200					
	20	29	36	42	46	49	52	54	57	58	60	62	63	64				
3	13150	12550	12550	12550	12550	12500	12500	12500	12450	12450	12450	12450	12400	12400	12400	12400		
	(2.9)	18	28	35	40	44	48	50	53	55	57	59	60	61	63	64		
3.5		11200	10500	10550	10500	10500	10500	10500	10450	10450	10450	10450	10450	10400	10400	10400	10400	10400
		(3.3)	17	27	34	39	43	46	49	51	54	55	57	59	60	61	62	63
4			9500	9000	9000	9000	9000	9000	8950	8950	8950	8950	8950	8950	8900	8900	8900	8900
			(3.8)	16	26	33	38	42	45	48	50	52	54	56	57	59	60	61
5				8200	7150	6850	6900	6900	6850	6850	6850	6850	6850	6850	6850	6800	6800	6800
				(4.3)	(4.8)	15	25	31	36	39	43	45	48	50	52	53	55	56
6						6350	5650	5450	5450	5450	5450	5450	5450	5450	5450	5450	5400	5400
						(5.3)	(5.8)	14	23	29	34	37	41	43	46	48	50	51
7								5050	4550	4450	4450	4450	4450	4450	4450	4450	4450	4450
								(6.3)	(6.8)	14	22	28	32	36	39	42	44	45
8										4150	3750	3700	3700	3700	3700	3700	3700	3700
										(7.3)	(7.8)	13	21	27	31	34	37	39
9												3400	3150	3100	3100	3100	3100	3100
												(8.3)	(8.8)	12	20	26	30	32
10														2850	2650	2600	2600	2600
														(9.3)	(9.8)	12	19	23
11																2400	2250	2200
																(10.3)	(10.8)	6
11.1																		2150
																		(11.1)

NOTE : WEIGHT OF HOOKS, BLOCKS & OTHER LOAD HANDLING DEVICES SHALL BE ADDED TO THE WEIGHT OF THE LOAD

MAC-25 LUG 2 LOAD CHART - 40 DEG. ART.

LMI DUTY

112

COUNTERWEIGHT ON FRONT OF CRANE - SPRING LOCKOUTS ENGAGED

█ S.W.L IN KILOGRAMS FOR SLEW ANGLES OF GREATER THAN 10 DEGREES UP TO 40 DEGREES EITHER SIDE OF STRAIGHT AHEAD (INDICATED BY RED LED ON DASH).
□ BOOM ANGLE - UNDEFLECTED (REF.)

S.W.L. ARE BASED ON 66.7% STABILITY & STRENGTH
 - S.W.L. ABOVE BOLD RED LINE ARE STRUCTURAL
 S.W.L. ARE BASED ON FIRM LEVEL GROUND (1% SLOPE (0.6 DEG) AS PER AS1418.5) WITH TYRES INFLATED AS PER NOTES

NOTE: VALUES IN BRACKETS () ARE ACTUAL RADIUS AT ZERO DEG. BOOM ANGLE.

ENSURE WINCH ROPE IS FULLY TENSIONED

LIFT & CARRY - THE S.W.L. SHALL BE CARRIED WITH THE MIN BOOM LENGTH & AS CLOSE TO THE GROUND AS POSSIBLE AT SPEEDS NOT IN EXCESS OF 0.4 M/SEC (1.44 KM/HR)

Radius in Metres	BOOM PIVOT TO LUG 2, 2nd EXTENSION, THIRD EXTENSION RETRACTED (METRES)																	
	(metres)																	
	5.57	6.00	6.50	7.00	7.50	8.00	8.50	9.00	9.50	10.00	10.50	11.00	11.50	12.00	12.50	13.00	13.50	13.77
1.4	24550	23850	22150	18400	17000	15850	14900	14100	13350									
	42	46	50	54	57	59	61	63	64									
2	17550	17550	17500	17500	16550	14050	13800	12950	12250	11650	11100	10600						
	32	38	43	47	51	54	56	58	60	62	63	64						
2.5	13700	13700	13700	13700	13650	13650	13200	12600	12100	11650	10300	9850	9450	9050				
	20	29	36	42	46	49	52	54	57	58	60	62	63	64				
3	11700	11150	11150	11150	11150	11150	11100	11100	10800	10350	10000	9650	9350	8400	8100	7800		
	(2.9)	18	28	35	40	44	48	50	53	55	57	59	60	61	63	64		
3.5		9950	9350	9350	9350	9300	9300	9300	9300	9250	9000	8700	8450	8200	7950	7250	7000	6850
		(3.3)	17	27	34	39	43	46	49	51	54	55	57	59	60	61	62	63
4			8400	7950	7950	7950	7950	7950	7950	7900	7900	7900	7650	7400	7200	7000	6850	6750
			(3.8)	16	26	33	38	42	45	48	50	52	54	56	57	59	60	61
5				7250	6300	6050	6050	6050	6050	6050	6050	6000	6000	6000	6000	5850	5700	5650
				(4.3)	(4.8)	15	25	31	36	39	43	45	48	50	52	53	55	56
6						5550	4900	4750	4750	4750	4750	4750	4750	4750	4750	4750	4750	4750
						(5.3)	(5.8)	14	23	29	34	37	41	43	46	48	50	51
7								4400	3950	3850	3850	3850	3850	3850	3850	3850	3850	3850
								(6.3)	(6.8)	14	22	28	32	36	39	42	44	45
8										3550	3200	3150	3150	3150	3150	3150	3150	3150
										(7.3)	(7.8)	13	21	27	31	34	37	39
9												2900	2650	2650	2650	2650	2650	2650
												(8.3)	(8.8)	12	20	26	30	32
10														2400	2200	2200	2200	2200
														(9.3)	(9.8)	12	19	23
11																2000	1850	1850
																(10.3)	(10.8)	6
11.1																		1750
																		(11.1)

NOTE : WEIGHT OF HOOKS, BLOCKS & OTHER LOAD HANDLING DEVICES SHALL BE ADDED TO THE WEIGHT OF THE LOAD

MAC-25 FALL BLOCK LOAD CHART - 10 DEG. ART

LMI DUTY **201**

COUNTERWEIGHT ON REAR OF CRANE - SPRING LOCKOUTS ENGAGED

█ S.W.L IN KILOGRAMS FOR SLEW ANGLES OF 10 DEGREES OR LESS EITHER SIDE OF STRAIGHT AHEAD (INDICATED BY GREEN LED ON DASH).

□ BOOM ANGLE - UNDEFLECTED (REF.)

NOTE : VALUES IN BRACKETS () ARE ACTUAL RADIUS AT ZERO DEG. BOOM ANGLE.

S.W.L. ARE BASED ON 66.7% STABILITY & STRENGTH

- S.W.L. ABOVE BOLD RED LINE ARE STRUCTURAL

S.W.L. ARE BASED ON FIRM LEVEL GROUND (1% SLOPE (0.6 DEG) AS PER AS1418.5)

WITH TYRES INFLATED AS PER NOTES

LIFT & CARRY - THE S.W.L. SHALL BE CARRIED WITH THE MINIMUM BOOM LENGTH & AS CLOSE TO THE GROUND AS POSSIBLE AT SPEEDS NOT IN EXCESS OF 0.4 M/SEC (1.44 KM/HR)

Radius in Metres	BOOM PIVOT TO HEAD SHEAVES - THIRD BOOM RETRACTED (metres)														THIRD BOOM EXTENDING (metres)											
	6.12	6.50	7.00	7.50	8.00	8.50	9.00	9.50	10.00	10.50	11.00	11.50	12.00	12.50	13.00	13.50	14.32	14.50	15.00	15.50	16.00	16.50	17.00	17.50	18.00	18.42
1.4	25000	25000	25000	25000	25000	25000	25000	25000																		
	48	51	54	57	59	61	63	65																		
2.0	23000	22950	22850	22950	22900	22850	22850	22800	22800	22150	19300															
	40	44	48	51	54	57	59	61	62	64	65															
2.5	18200	18150	18150	18100	18050	18000	18000	17950	17950	17900	17750	15550	14600													
	32	37	42	46	50	52	55	57	59	61	62	63	65													
3.0	14900	14900	14900	14850	14800	14800	14750	14750	14700	14700	14700	14350	13500	13000	12600	12250										
	21	29	35	41	45	48	51	53	55	57	59	61	62	63	64	65										
3.5	12900	12550	12550	12500	12500	12450	12450	12400	12400	12400	12350	12350	12150	11750	11400	10850	10750									
	(3.4)	17	28	34	39	43	47	49	52	54	56	58	59	61	62	63	65	65								
4.0		11450	10800	10750	10750	10700	10700	10700	10650	10650	10650	10600	10600	10600	10600	10100	10050	9850	9650							
		(3.8)	17	27	33	38	42	45	48	51	53	55	56	58	59	61	62	63	64	65						
5.0			9900	8700	8300	8300	8300	8250	8250	8250	8250	8200	8200	8200	8200	8200	8150	8200	8200	8250	8300	8250	8150	8000	7900	
			(4.3)	(4.8)	16	25	31	36	40	43	46	48	50	52	54	56	58	58	59	61	62	63	63	64	65	
6.0					7700	6900	6650	6650	6650	6600	6600	6600	6600	6600	6600	6550	6550	6550	6600	6650	6700	6750	6750	6800	6800	6850
					(5.3)	(5.8)	15	24	30	34	38	41	44	46	48	50	53	53	55	56	57	58	60	61	62	
7.0							6250	5650	5450	5450	5450	5450	5450	5400	5400	5400	5400	5400	5450	5500	5550	5550	5600	5650	5650	5700
							(6.3)	(6.8)	14	23	28	33	36	39	42	44	48	48	50	52	53	54	56	57	58	59
8.0									5150	4700	4550	4550	4550	4550	4550	4550	4550	4550	4600	4650	4650	4700	4750	4750	4800	4800
									(7.3)	(7.8)	13	22	27	31	35	38	42	43	45	47	48	50	51	53	54	55
9.0											4350	4000	3900	3900	3900	3900	3850	3900	3900	3950	4000	4050	4050	4100	4100	4150
											(8.3)	(8.8)	13	21	26	30	35	36	39	41	43	45	47	48	50	51
10												3700	3400	3350	3350	3350	3350	3400	3400	3450	3500	3500	3550	3550	3600	
												(9.3)	(9.8)	12	20	28	29	32	35	38	40	42	44	45	47	
11															3200	2950	2900	2900	2950	3000	3000	3050	3050	3100	3150	3150
															(10.3)	(10.8)	17	19	24	28	31	34	37	39	41	42
12																	2650	2600	2550	2600	2650	2650	2700	2750	2750	2800
																	(11.6)	(11.8)	12	19	23	27	30	33	36	37
13																			2450	2350	2300	2350	2400	2400	2450	2450
																		(12.3)	(12.8)	11	18	23	27	30	32	
14																					2200	2100	2100	2150	2150	2200
																			(13.3)	(13.8)	11	18	22	25		
15																							2050	1950	1950	1950
																						(14.3)	(14.8)	10	16	
15.71																									1850	1800
																									(15.3)	(15.7)

NOTE : WEIGHT OF HOOKS, BLOCKS & OTHER LOAD HANDLING DEVICES SHALL BE ADDED TO THE WEIGHT OF THE LOAD

MAC-25 FALL BLOCK LOAD CHART - 40 DEG. ART.

COUNTERWEIGHT ON REAR OF CRANE - SPRING LOCKOUTS ENGAGED

S.W.L. IN KILOGRAMS FOR SLEW ANGLES OF GREATER THAN 10 DEGREES UP TO 40 DEGREES EITHER SIDE OF STRAIGHT AHEAD (INDICATED BY RED LED ON DASH).
BOOM ANGLE - UNDEFLECTED (REF.)

LMI DUTY **201**

S.W.L. ARE BASED ON 66.7% STABILITY & STRENGTH

- S.W.L. ABOVE BOLD RED LINE ARE STRUCTURAL

S.W.L. ARE BASED ON FIRM LEVEL GROUND (1% SLOPE (0.6 DEG) AS PER AS1418.5) WITH TYRES INFLATED AS PER NOTES

LIFT & CARRY - THE S.W.L. SHALL BE CARRIED WITH THE MINIMUM BOOM LENGTH & AS CLOSE TO THE GROUND AS POSSIBLE AT SPEEDS NOT IN EXCESS OF 0.4 M/SEC (1.44 KM/HR)

NOTE : VALUES IN BRACKETS () ARE ACTUAL RADIUS AT ZERO DEG. BOOM ANGLE.

Radius in Metres	BOOM PIVOT TO HEAD SHEAVES - THIRD BOOM RETRACTED (metres)														THIRD BOOM EXTENDING (metres)											
	6.12	6.50	7.00	7.50	8.00	8.50	9.00	9.50	10.00	10.50	11.00	11.50	12.00	12.50	13.00	13.50	14.32	14.50	15.00	15.50	16.00	16.50	17.00	17.50	18.00	18.42
1.4	21750	20200	18550	17250	16150	15200	14400	13700																		
	48	51	54	57	59	61	63	65																		
2.0	19850	18700	17500	16150	15000	14100	13300	12600	12000	11450	10950															
	40	44	48	51	54	57	59	61	62	64	65															
2.5	16250	16250	15600	14700	13900	13200	12400	11750	11150	10650	10200	9800	9400													
	32	37	42	46	50	52	55	57	59	61	62	63	65													
3.0	13300	13300	13250	13250	12500	11900	11400	10900	10400	9900	9500	9100	8750	8450	8150	7850										
	21	29	35	41	45	48	51	53	55	57	59	61	62	63	64	65										
3.5	11450	11150	11150	11150	11100	10800	10300	9900	9500	9200	8800	8450	8150	7850	7600	7350	6950	6900								
	(3.4)	17	28	34	39	43	47	49	52	54	56	58	59	61	62	63	65	65								
4.0		10150	9550	9550	9550	9550	9400	9000	8650	8350	8100	7850	7550	7300	7050	6850	6500	6450	6300	6150						
		(3.8)	17	27	33	38	42	45	48	51	53	55	56	58	59	61	62	63	64	65						
5.0			8750	7700	7350	7300	7300	7300	7300	7100	6850	6600	6400	6250	6100	5950	5650	5600	5500	5400	5300	5200	5100	5050	4950	
			(4.3)	(4.8)	16	25	31	36	40	43	46	48	50	52	54	56	58	58	59	61	62	63	63	64	65	
6.0				6800	6100	5850	5850	5800	5800	5800	5700	5550	5350	5200	5100	4900	4850	4800	4750	4650	4600	4550	4450	4400	4350	
				(5.3)	(5.8)	15	24	30	34	38	41	44	46	48	50	53	53	55	56	57	58	60	61	61	62	
7.0					5450	4950	4750	4750	4750	4750	4750	4750	4700	4550	4450	4250	4250	4200	4150	4100	4050	4000	3950	3900	3850	
					(6.3)	(6.8)	14	23	28	33	36	39	42	44	48	48	50	52	53	54	56	57	58	59		
8.0							4500	4100	3950	3950	3950	3950	3950	3950	3900	3750	3750	3700	3650	3600	3600	3550	3500	3500	3450	
							(7.3)	(7.8)	13	22	27	31	35	38	42	43	45	47	48	50	51	53	54	55		
9.0										3750	3450	3350	3350	3350	3350	3350	3350	3300	3250	3200	3200	3150	3150	3100	3100	
										(8.3)	(8.8)	13	21	26	30	35	36	39	41	43	45	47	48	50	51	
10											3150	2950	2850	2850	2850	2850	2900	2900	2900	2850	2850	2800	2800	2750		
										(9.3)	(9.8)	12	20	28	29	32	35	38	40	42	44	44	45	47		
11														2700	2500	2450	2450	2500	2550	2550	2600	2550	2550	2500	2500	
														(10.3)	(10.8)	17	19	24	28	31	34	37	39	41	42	
12																2200	2150	2150	2200	2250	2250	2300	2300	2300	2300	
																(11.6)	(11.8)	12	19	23	27	30	33	36	37	
13																		2050	1950	1950	2000	2000	2050	2050	2100	
																	(12.3)	(12.8)	11	18	23	27	30	32		
14																			1850	1750	1750	1800	1800	1850		
																		(13.3)	(13.8)	11	18	22	25			
15																						1700	1600	1600	1650	
																					(14.3)	(14.8)	10	16		
15.71																								1550	1500	
																								(15.3)	(15.7)	

NOTE : WEIGHT OF HOOKS, BLOCKS & OTHER LOAD HANDLING DEVICES SHALL BE ADDED TO THE WEIGHT OF THE LOAD

MAC-25 RHINO HOOK LOAD CHART - 10 DEG

LMI DUTY **202**

COUNTERWEIGHT ON REAR OF CRANE - SPRING LOCKOUTS ENGAGED

S.W.L. ARE BASED ON 66.7% STABILITY & STRENGTH

Yellow Box S.W.L. IN KILOGRAMS FOR SLEW ANGLES OF 10 DEGREES OR LESS EITHER SIDE OF STRAIGHT AHEAD (INDICATED BY GREEN LED ON DASH).

- S.W.L. ABOVE BOLD RED LINE ARE STRUCTURAL

White Box BOOM ANGLE - UNDEFLECTED (REF.)

S.W.L. ARE BASED ON FIRM LEVEL GROUND (1% SLOPE (0.6 DEG) AS PER AS1418.5) WITH TYRES INFLATED AS PER NOTES

NOTE : VALUES IN BRACKETS () ARE ACTUAL RADIUS AT ZERO DEG. BOOM ANGLE.

LIFT & CARRY - THE S.W.L. SHALL BE CARRIED WITH THE MINIMUM BOOM LENGTH & AS CLOSE TO THE GROUND AS POSSIBLE AT SPEEDS NOT IN EXCESS OF 0.4 M/SEC (1.44 KM/HR)

Radius in Metres	BOOM PIVOT TO HOOK CENTRE - THIRD BOOM RETRACTED (metres)														THIRD BOOM EXTENDING (metres)														
	6.45	7.00	7.50	8.00	8.50	9.00	9.50	10.00	10.50	11.00	11.50	12.00	12.50	13.00	13.50	14.00	14.65	15.00	15.50	16.00	16.50	17.00	17.50	18.00	18.50	18.75			
1.4	15000	15000	15000	15000	15000	15000	15000																						
	51	55	58	60	62	64	65																						
2.0	15000	15000	15000	15000	15000	15000	15000	15000	15000	15000																			
	44	49	52	55	57	59	61	63	64	65																			
2.5	15000	15000	15000	15000	15000	15000	15000	15000	15000	15000	15000	14200																	
	37	43	47	50	53	56	58	59	61	63	64	65																	
3.0	15000	15000	15000	15000	14950	14900	14900	14850	14850	14800	14800	13200	12750	12300															
	29	36	41	45	49	52	54	56	58	60	61	62	64	65															
3.5	12700	12700	12650	12650	12600	12600	12550	12550	12500	12500	12500	12300	11850	11450	11150	10800													
	17	29	35	40	44	47	50	52	55	56	58	60	61	62	63	64													
4.0	11750	10900	10900	10900	10850	10850	10800	10800	10800	10750	10750	10750	10700	10700	10400	10100	9750	9600	9450										
	(3.7)	18	28	34	39	43	46	49	51	53	55	57	58	60	61	62	63	64	65										
5.0		10050	8800	8400	8400	8400	8350	8350	8350	8300	8300	8300	8300	8250	8250	8250	8250	8250	8300	8200	8050	7900	7800	7700					
		(4.3)	(4.8)	16	26	32	37	40	44	46	49	51	53	54	56	57	59	60	61	62	63	64	65	65					
6.0			7800	7000	6750	6700	6700	6700	6700	6700	6650	6650	6650	6650	6650	6600	6650	6700	6700	6750	6800	6800	6850	6800	6650	6650			
			(5.3)	(5.8)	15	24	30	35	38	42	44	47	49	51	52	54	55	57	58	59	60	61	62	63	63				
7.0					6300	5750	5550	5550	5500	5500	5500	5500	5500	5500	5450	5450	5500	5550	5550	5600	5650	5650	5700	5700	5700				
					(6.3)	(6.8)	15	23	29	33	37	40	42	45	47	49	50	52	53	55	56	57	58	59	60				
8.0							5200	4800	4650	4650	4650	4600	4600	4600	4600	4600	4600	4650	4700	4700	4750	4800	4800	4850	4850				
							(7.3)	(7.8)	14	22	28	32	35	38	41	44	45	47	49	50	52	53	54	55	56				
9.0									4400	4050	3950	3950	3950	3950	3900	3900	3950	4000	4000	4050	4050	4100	4150	4150	4150				
									(8.3)	(8.8)	13	21	27	31	34	38	39	42	44	46	47	49	50	51	52				
10											3750	3450	3350	3350	3350	3350	3400	3450	3450	3500	3550	3550	3600	3600	3600				
											(9.3)	(9.8)	13	20	26	31	33	36	38	40	42	44	46	47	48				
11																	3200	3000	2900	2900	2950	3000	3000	3050	3100	3150			
																	(10.3)	(10.8)	12	21	25	29	32	35	37	39	41	43	44
12																		2800	2550	2550	2600	2650	2700	2700	2750	2800	2800		
																		(11.3)	(11.9)	12	19	24	28	31	34	36	38	39	
13																			2450	2350	2300	2350	2400	2400	2450	2450	2500		
																			(12.3)	(12.8)	12	18	23	27	30	33	34		
14																				2200	2100	2100	2150	2150	2200	2200			
																				(13.3)	(13.8)	11	18	23	26	28			
15																							2000	1950	1950	1950			
																							(14.3)	(14.8)	11	17	20		
16																									1850	1750	1750		
																									(15.3)	(15.8)	(16.)		

NOTE : WEIGHT OF HOOKS, BLOCKS & OTHER LOAD HANDLING DEVICES SHALL BE ADDED TO THE WEIGHT OF THE LOAD

MAC-25 RHINO HOOK LOAD CHART - 40 DEG

LMI DUTY **202**

COUNTERWEIGHT ON REAR OF CRANE - SPRING LOCKOUTS ENGAGED

S.W.L. ARE BASED ON 66.7% STABILITY & STRENGTH



S.W.L. IN KILOGRAMS FOR SLEW ANGLES OF GREATER THAN 10 DEGREES UP TO 40 DEGREES EITHER SIDE OF STRAIGHT AHEAD (INDICATED BY RED LED ON DASH).

- S.W.L. ABOVE BOLD RED LINE ARE STRUCTURAL



BOOM ANGLE - UNDEFLECTED (REF.)

S.W.L. ARE BASED ON FIRM LEVEL GROUND (1% SLOPE (0.6 DEG) AS PER AS1418.5) WITH TYRES INFLATED AS PER NOTES

NOTE : VALUES IN BRACKETS () ARE ACTUAL RADIUS AT ZERO DEG. BOOM ANGLE.

LIFT & CARRY - THE S.W.L. SHALL BE CARRIED WITH THE MINIMUM BOOM LENGTH & AS CLOSE TO THE GROUND AS POSSIBLE AT SPEEDS NOT IN EXCESS OF 0.4 M/SEC (1.44 KM/HR)

Radius in Metres	BOOM PIVOT TO HOOK CENTRE - THIRD BOOM RETRACTED (metres)														THIRD BOOM EXTENDING (metres)											
	6.45	7.00	7.50	8.00	8.50	9.00	9.50	10.00	10.50	11.00	11.50	12.00	12.50	13.00	13.50	14.00	14.65	15.00	15.50	16.00	16.50	17.00	17.50	18.00	18.50	18.75
1.4	15000	15000	15000	15000	15000	14500	13800																			
	51	55	58	60	62	64	65																			
2.0	15000	15000	15000	15000	14200	13400	12700	12100	11550	11050																
	44	49	52	55	57	59	61	63	64	65																
2.5	15000	15000	14850	14050	13300	12500	11850	11250	10750	10300	9850	9500														
	37	43	47	50	53	56	58	59	61	63	64	65														
3.0	13500	13450	13400	12650	12050	11500	11050	10500	10000	9550	9150	8800	8500	8200												
	29	36	41	45	49	52	54	56	58	60	61	62	64	65												
3.5	11350	11300	11300	11250	10900	10400	10000	9600	9300	8900	8550	8200	7900	7650	7400	7150										
	17	29	35	40	44	47	50	52	55	56	58	60	61	62	63	64										
4.0	10450	9700	9700	9700	9650	9500	9100	8750	8450	8200	7900	7650	7350	7100	6900	6650	6400	6300	6200							
	(3.7)	18	28	34	39	43	46	49	51	53	55	57	58	60	61	62	63	64	65							
5.0		8900	7800	7450	7450	7400	7400	7400	7150	6900	6700	6500	6300	6150	6000	5800	5600	5500	5400	5300	5200	5150	5050	4950		
		(4.3)	(4.8)	16	26	32	37	40	44	46	49	51	53	54	56	57	59	60	61	62	63	64	65	65		
6.0				6900	6150	5900	5900	5900	5900	5900	5750	5600	5450	5300	5150	5000	4850	4850	4750	4700	4600	4550	4450	4400	4350	4300
				(5.3)	(5.8)	15	24	30	35	38	42	44	47	49	51	52	54	55	57	58	59	60	61	62	63	63
7.0						5550	5000	4850	4850	4850	4800	4800	4750	4600	4500	4350	4250	4200	4150	4100	4050	4000	4000	3900	3850	3850
						(6.3)	(6.8)	15	23	29	33	37	40	42	45	47	49	50	52	53	55	56	57	58	59	60
8.0								4550	4150	4000	4000	4000	4000	4000	3950	3850	3750	3700	3650	3650	3600	3550	3500	3500	3450	3450
								(7.3)	(7.8)	14	22	28	32	35	38	41	44	45	47	49	50	52	53	54	55	56
9.0										3800	3500	3400	3400	3400	3400	3400	3300	3300	3250	3250	3200	3150	3150	3100	3100	3050
										(8.3)	(8.8)	13	21	27	31	34	38	39	42	44	46	47	49	50	51	52
10											3200	2950	2900	2900	2900	2900	2900	2900	2950	2900	2850	2850	2800	2800	2750	2750
											(9.3)	(9.8)	13	20	26	31	33	36	38	40	42	44	46	47	48	
11														2750	2550	2450	2500	2500	2550	2600	2600	2550	2550	2500	2500	
														(10.3)	(10.8)	12	21	25	29	32	35	37	39	41	44	
12																	2350	2150	2150	2200	2250	2300	2300	2300	2250	
																	(11.3)	(11.9)	12	19	24	28	31	34	38	39
13																		2050	1950	1950	2000	2000	2050	2050	2100	2100
																	(12.3)	(12.8)	12	18	23	27	30	33	34	
14																				1850	1750	1750	1800	1800	1850	1850
																			(13.3)	(13.8)	11	18	23	26	28	
15																							1700	1600	1650	1650
																					(14.3)	(14.8)	11	17	20	
16																								1550	1450	1450
																							(15.3)	(15.8)	(16.)	

NOTE : WEIGHT OF HOOKS, BLOCKS & OTHER LOAD HANDLING DEVICES SHALL BE ADDED TO THE WEIGHT OF THE LOAD

MAC-25 OFFSET HEAD BOTTOM POSITION LOAD CHART - 10 DEG

LMI DUTY **203**

COUNTERWEIGHT ON REAR OF CRANE - SPRING LOCKOUTS ENGAGED

S.W.L. ARE BASED ON 66.7% STABILITY & STRENGTH

Yellow Box S.W.L IN KILOGRAMS FOR SLEW ANGLES OF 10 DEGREES OR LESS EITHER SIDE OF STRAIGHT AHEAD (INDICATED BY GREEN LED ON DASH).

- S.W.L. ABOVE BOLD RED LINE ARE STRUCTURAL

White Box BOOM ANGLE - UNDEFLECTED (REF.)

S.W.L. ARE BASED ON FIRM LEVEL GROUND (1% SLOPE (0.6 DEG) AS PER AS1418.5) WITH TYRES INFLATED AS PER NOTES

NOTE : VALUES IN BRACKETS () ARE ACTUAL RADIUS AT ZERO DEG. BOOM ANGLE.

LIFT & CARRY - THE S.W.L. SHALL BE CARRIED WITH THE MINIMUM BOOM LENGTH & AS CLOSE TO THE GROUND AS POSSIBLE AT SPEEDS NOT IN EXCESS OF 0.4 M/SEC (1.44 KM/HR)

Radius in Metres	BOOM PIVOT TO EDGE OF SHEAVE - THIRD BOOM RETRACTED (metres)															THIRD BOOM EXTENDING (metres)															
	6.86	7.00	7.50	8.00	8.50	9.00	9.50	10.00	10.50	11.00	11.50	12.00	12.50	13.00	13.50	14.00	14.50	15.06	15.50	16.00	16.50	17.00	17.50	18.00	18.50	19.16					
1.4	8400	8400	8400	8400	8400	8400																									
	55	56	59	61	63	65																									
2.0	8400	8400	8400	8400	8400	8400	8400	8400	8400													WINCH S.W.L.									
	49	50	53	56	58	60	62	64	65																	SINGLE PART		4200			
2.5	8400	8400	8400	8400	8400	8400	8400	8400	8400	8400	8400											TWO PART				8400					
	43	44	48	51	54	56	58	60	62	63	65																				
3.0	8400	8400	8400	8400	8400	8400	8400	8400	8400	8400	8400	8400	8400	8400																	
	36	38	43	46	50	52	55	57	59	60	62	63	64	65																	
3.5	8400	8400	8400	8400	8400	8400	8400	8400	8400	8400	8400	8400	8400	8400	8400																
	27	30	36	41	45	48	51	53	55	57	59	60	62	63	64	65															
4.0	8400	8400	8400	8400	8400	8400	8400	8400	8400	8400	8400	8400	8400	8400	8400	8400	8400	8400													
	(4.2)	19	29	35	40	44	47	50	52	54	56	58	59	60	62	63	64	65													
5.0		8400	8400	8400	8400	8400	8400	8400	8400	8400	8400	8400	8400	8400	8400	8350	8350	8350	8350	8350	8350	8250	8100	8000							
		(4.3)	(4.8)	18	27	33	38	41	44	47	49	52	53	55	57	58	59	61	61	62	63	64	65								
6.0				7950	7100	6850	6850	6850	6800	6800	6750	6750	6750	6750	6700	6700	6750	6750	6800	6850	6850	6900	6500	5850							
				(5.3)	(5.8)	17	25	31	36	39	42	45	47	49	51	53	54	56	57	58	59	60	61	62	63	64					
7.0						6400	5800	5650	5650	5600	5600	5600	5600	5550	5550	5550	5550	5550	5600	5650	5650	5700	5700	5750	5800						
						(6.3)	(6.8)	16	24	30	34	37	40	43	45	47	49	51	52	54	55	56	57	59	59	61					
8.0								5300	4850	4700	4700	4700	4700	4700	4700	4700	4650	4650	4700	4750	4750	4800	4800	4850	4850	4900					
								(7.3)	(7.8)	15	23	28	33	36	39	41	44	46	48	49	51	52	53	55	56	57					
9.0										4450	4100	4000	4000	4000	4000	4000	4000	4000	4000	4050	4050	4100	4150	4150	4200	4200					
										(8.3)	(8.8)	14	22	27	31	35	37	40	42	44	46	48	49	51	52	53					
10												3800	3550	3450	3450	3450	3450	3450	3450	3500	3550	3550	3600	3600	3650	3650					
												(9.3)	(9.8)	14	21	26	30	34	36	39	41	43	45	46	48	50					
11																			3300	3050	3000	3000	3000	3100	3100	3150	3200	3200			
																			(10.3)	(10.8)	13	20	26	29	32	35	37	40	42	43	45
12																				2850	2650	2600	2650	2700	2750	2800	2800	2850			
																				(11.3)	(11.8)	14	20	24	28	31	34	36	39	41	
13																					2450	2350	2350	2350	2400	2450	2450	2500	2500		
																				(12.4)	(12.8)	12	19	24	27	30	33	36			
14																					2250	2150	2100	2150	2200	2200	2250				
																					(13.3)	(13.8)	12	18	23	27	30				
15																							2050	1950	1950	1950	2000				
																							(14.3)	(14.8)	12	18	24				
16.4																									1850	1800	1700				
																									(15.3)	(15.8)	(16.4)				

MAC-25 OFFSET HEAD BOTTOM POSITION LOAD CHART - 40 DEG

LMI DUTY **203**

COUNTERWEIGHT ON REAR OF CRANE - SPRING LOCKOUTS ENGAGED

S.W.L. ARE BASED ON 66.7% STABILITY & STRENGTH

Yellow Box S.W.L IN KILOGRAMS FOR SLEW ANGLES OF GREATER THAN 10 DEGREES UP TO 40 DEGREES EITHER SIDE OF STRAIGHT AHEAD (INDICATED BY RED LED ON DASH).

- S.W.L. ABOVE BOLD RED LINE ARE STRUCTURAL

White Box BOOM ANGLE - UNDEFLECTED (REF.)

S.W.L. ARE BASED ON FIRM LEVEL GROUND (1% SLOPE (0.6 DEG) AS PER AS1418.5) WITH TYRES INFLATED AS PER NOTES

NOTE : VALUES IN BRACKETS () ARE ACTUAL RADIUS AT ZERO DEG. BOOM ANGLE.

LIFT & CARRY - THE S.W.L. SHALL BE CARRIED WITH THE MINIMUM BOOM LENGTH & AS CLOSE TO THE GROUND AS POSSIBLE AT SPEEDS NOT IN EXCESS OF 0.4 M/SEC (1.44 KM/HR)

Radius in Metres	BOOM PIVOT TO EDGE OF SHEAVE - THIRD BOOM RETRACTED (metres)															THIRD BOOM EXTENDING (metres)										
	6.86	7.00	7.50	8.00	8.50	9.00	9.50	10.00	10.50	11.00	11.50	12.00	12.50	13.00	13.50	14.00	14.50	15.06	15.50	16.00	16.50	17.00	17.50	18.00	18.50	19.16
1.4	8400	8400	8400	8400	8400	8400																				
	55	56	59	61	63	65																				
2.0	8400	8400	8400	8400	8400	8400	8400	8400	8400													WINCH S.W.L.				
	49	50	53	56	58	60	62	64	65																SINGLE PART	4200
2.5	8400	8400	8400	8400	8400	8400	8400	8400	8400	8400	8400											TWO PARTS			8400	
	43	44	48	51	54	56	58	60	62	63	65															
3.0	8400	8400	8400	8400	8400	8400	8400	8400	8400	8400	8400	8400	8400	8300												
	36	38	43	46	50	52	55	57	59	60	62	63	64	65												
3.5	8400	8400	8400	8400	8400	8400	8400	8400	8400	8400	8400	8300	8000	7750	7500	7250										
	27	30	36	41	45	48	51	53	55	57	59	60	62	63	64	65										
4.0	8400	8400	8400	8400	8400	8400	8400	8400	8400	8300	8050	7750	7450	7200	7000	6750	6550	6350								
	(4.2)	19	29	35	40	44	47	50	52	54	56	58	59	60	62	63	64	65								
5.0		8400	7950	7600	7550	7550	7500	7300	7050	6800	6600	6400	6250	6100	5900	5750	5550	5450	5350	5250	5150	5050				
		(4.3)	(4.8)	18	27	33	38	41	44	47	49	52	53	55	57	58	59	61	61	62	63	64	65			
6.0			7050	6300	6050	6050	6000	6000	6000	5900	5700	5550	5350	5250	5100	5000	4850	4800	4700	4650	4550	4500	4450	4450	4350	4300
			(5.3)	(5.8)	17	25	31	36	39	42	45	47	49	51	53	54	56	57	58	59	60	61	62	63	64	
7.0					5650	5100	4950	4950	4950	4900	4850	4700	4550	4450	4350	4250	4200	4150	4100	4050	4000	3950	3900	3850	3850	
					(6.3)	(6.8)	16	24	30	34	37	40	43	45	47	49	51	52	54	55	56	57	59	59	61	
8.0							4650	4250	4100	4100	4100	4100	4100	4050	3950	3850	3750	3700	3650	3600	3600	3550	3500	3500	3450	
							(7.3)	(7.8)	15	23	28	33	36	39	41	44	46	48	49	51	52	53	55	56	57	
9.0									3900	3550	3450	3450	3450	3450	3450	3300	3300	3250	3200	3200	3150	3150	3100	3100	3050	
									(8.3)	(8.8)	14	22	27	31	35	37	40	42	44	46	48	49	51	52	53	
10											3300	3050	2950	2950	2950	2950	2950	2950	2900	2900	2850	2850	2800	2800	2750	
											(9.3)	(9.8)	14	21	26	30	34	36	39	41	43	45	46	48	50	
11														2800	2600	2550	2550	2550	2550	2600	2600	2600	2550	2550	2500	
														(10.3)	(10.8)	13	20	26	29	32	35	37	40	42	45	
12																2400	2250	2200	2200	2300	2300	2350	2300	2300	2300	
																(11.3)	(11.8)	14	20	24	28	31	34	36	39	41
13																	2050	1950	1950	2000	2050	2050	2100	2100	2100	
																(12.4)	(12.8)	12	19	24	27	30	33	36	36	
14																			1850	1800	1800	1800	1850	1850	1900	
																			(13.3)	(13.8)	12	18	23	27	30	
15																						1700	1600	1600	1700	
																						(14.3)	(14.8)	12	18	24
16.4																								1550	1500	1400
																								(15.3)	(15.8)	(16.4)

MAC-25 OFFSET HEAD TOP POSITION LOAD CHART - 10 DEG

LMI DUTY **204**

COUNTERWEIGHT ON REAR OF CRANE - SPRING LOCKOUTS ENGAGED

S.W.L. ARE BASED ON 66.7% STABILITY & STRENGTH

Yellow Box S.W.L IN KILOGRAMS FOR SLEW ANGLES OF 10 DEGREES OR LESS EITHER SIDE OF STRAIGHT AHEAD (INDICATED BY GREEN LED ON DASH).

- S.W.L. ABOVE BOLD RED LINE ARE STRUCTURAL

White Box BOOM ANGLE - UNDEFLECTED (REF.)

S.W.L. ARE BASED ON FIRM LEVEL GROUND (1% SLOPE (0.6 DEG) AS PER AS1418.5) WITH TYRES INFLATED AS PER NOTES

NOTE : VALUES IN BRACKETS () ARE ACTUAL RADIUS AT ZERO DEG. BOOM ANGLE.

LIFT & CARRY - THE S.W.L. SHALL BE CARRIED WITH THE MINIMUM BOOM LENGTH & AS CLOSE TO THE GROUND AS POSSIBLE AT SPEEDS NOT IN EXCESS OF 0.4 M/SEC (1.44 KM/HR)

Radius in Metres	BOOM PIVOT TO EDGE OF SHEAVE - THIRD BOOM RETRACTED (metres)															THIRD BOOM EXTENDING (metres)																	
	6.82	7.00	7.50	8.00	8.50	9.00	9.50	10.00	10.50	11.00	11.50	12.00	12.50	13.00	13.50	14.00	14.50	15.02	15.50	16.00	16.50	17.00	17.50	18.00	18.50	19.12							
1.4	8400	8400	8400	8400	8400	8400	8400																										
	52	53	56	58	60	62	64																										
2.0	8400	8400	8400	8400	8400	8400	8400	8400	8400	8400																							
	45	47	50	53	56	58	60	61	63	64																							
2.5	8400	8400	8400	8400	8400	8400	8400	8400	8400	8400	8400	8400																					
	39	41	45	49	52	54	56	58	60	61	63	64																					
3.0	8400	8400	8400	8400	8400	8400	8400	8400	8400	8400	8400	8400	8400	8400	8400																		
	32	34	40	44	47	50	53	55	57	58	60	61	63	64	65																		
3.5	8400	8400	8400	8400	8400	8400	8400	8400	8400	8400	8400	8400	8400	8400	8400	8400																	
	24	27	33	38	42	46	49	51	53	55	57	59	60	61	62	63	64																
4.0	8400	8400	8400	8400	8400	8400	8400	8400	8400	8400	8400	8400	8400	8400	8400	8400	8400	8400	8400														
	(4.1)	16	26	32	37	41	45	47	50	52	54	56	57	59	60	61	62	63	64														
5.0		8400	8400	8400	8400	8400	8400	8400	8400	8400	8350	8350	8300	8300	8300	8250	8250	8250	8250	8250	8300	8300	8200	8050	7950								
		(4.3)	(4.8)	15	24	30	35	39	42	45	48	50	52	53	55	56	58	59	60	61	62	63	64	65									
6.0				7950	7100	6800	6800	6800	6750	6750	6700	6700	6700	6700	6650	6650	6650	6600	6650	6700	6750	6750	6800	6800	6850	6300							
				(5.3)	(5.8)	14	23	29	34	37	40	43	46	48	50	51	53	54	56	57	58	59	60	61	62	63							
7.0						6400	5800	5600	5600	5550	5550	5550	5550	5500	5500	5500	5500	5450	5500	5550	5550	5600	5650	5650	5700	5700							
						(6.3)	(6.8)	14	22	28	32	36	39	41	44	46	48	50	51	53	54	55	56	57	58	59							
8.0								5300	4850	4700	4700	4650	4650	4650	4650	4650	4600	4600	4650	4700	4700	4750	4750	4800	4800	4850							
								(7.3)	(7.8)	13	21	27	31	34	37	40	42	44	46	48	49	51	52	53	55	56							
9.0										4450	4100	4000	4000	3950	3950	3950	3950	3950	3950	4000	4050	4050	4100	4100	4150	4150							
										(8.3)	(8.8)	12	20	25	30	33	36	39	41	43	45	46	48	49	51	52							
10												3800	3500	3400	3400	3400	3400	3400	3450	3450	3500	3500	3550	3550	3600	3650							
												(9.3)	(9.8)	12	19	25	29	32	35	37	40	42	43	45	47	48							
11																			3250	3050	2950	2950	2950	3000	3000	3050	3100	3100	3150	3150	3200		
																			(10.3)	(10.8)	12	19	24	28	31	34	36	38	40	42	44		
12																				2850	2650	2550	2600	2650	2700	2700	2750	2800	2800				
																				(11.3)	(11.8)	12	18	23	27	30	33	35	37	40			
13																						2450	2350	2350	2350	2400	2400	2450	2450	2500			
																				(12.3)	(12.8)	11	18	22	26	29	32	35					
14																						2250	2150	2100	2150	2150	2200	2200					
																						(13.3)	(13.8)	11	17	22	25	29					
15																								2050	1950	1950	1950	2000					
																								(14.3)	(14.8)	10	17	22					
16.45																										1850	1800	1700					
																										(15.3)	(15.8)	(16.5)					

MAC-25 OFFSET HEAD TOP POSITION LOAD CHART - 40 DEG

LMI DUTY **204**

COUNTERWEIGHT ON REAR OF CRANE - SPRING LOCKOUTS ENGAGED

S.W.L. ARE BASED ON 66.7% STABILITY & STRENGTH

Yellow Box S.W.L IN KILOGRAMS FOR SLEW ANGLES OF GREATER THAN 10 DEGREES UP TO 40 DEGREES EITHER SIDE OF STRAIGHT AHEAD (INDICATED BY RED LED ON DASH).

- S.W.L. ABOVE BOLD RED LINE ARE STRUCTURAL

White Box BOOM ANGLE - UNDEFLECTED (REF.)

S.W.L. ARE BASED ON FIRM LEVEL GROUND (1% SLOPE (0.6 DEG) AS PER AS1418.5) WITH TYRES INFLATED AS PER NOTES

NOTE : VALUES IN BRACKETS () ARE ACTUAL RADIUS AT ZERO DEG. BOOM ANGLE.

LIFT & CARRY - THE S.W.L. SHALL BE CARRIED WITH THE MINIMUM BOOM LENGTH & AS CLOSE TO THE GROUND AS POSSIBLE AT SPEEDS NOT IN EXCESS OF 0.4 M/SEC (1.44 KM/HR)

Radius in Metres	BOOM PIVOT TO EDGE OF SHEAVE - THIRD BOOM RETRACTED (metres)															THIRD BOOM EXTENDING (metres)												
	6.82	7.00	7.50	8.00	8.50	9.00	9.50	10.00	10.50	11.00	11.50	12.00	12.50	13.00	13.50	14.00	14.50	15.02	15.50	16.00	16.50	17.00	17.50	18.00	18.50	19.12		
1.4	8400	8400	8400	8400	8400	8400	8400																					
	52	53	56	58	60	62	64																					
2.0	8400	8400	8400	8400	8400	8400	8400	8400	8400	8400												WINCH S.W.L.						
	45	47	50	53	56	58	60	61	63	64																		
2.5	8400	8400	8400	8400	8400	8400	8400	8400	8400	8400	8400	8400										TWO PARTS						
	39	41	45	49	52	54	56	58	60	61	63	64																
3.0	8400	8400	8400	8400	8400	8400	8400	8400	8400	8400	8400	8400	8400	8250	7950													
	32	34	40	44	47	50	53	55	57	58	60	61	63	64	65													
3.5	8400	8400	8400	8400	8400	8400	8400	8400	8400	8400	8400	8400	8250	7950	7650	7400	7200	6950										
	24	27	33	38	42	46	49	51	53	55	57	59	60	61	62	63	64											
4.0	8400	8400	8400	8400	8400	8400	8400	8400	8400	8400	8250	7950	7700	7400	7150	6900	6700	6500	6300	6150								
	(4.1)	16	26	32	37	41	45	47	50	52	54	56	57	59	60	61	62	63	64									
5.0		8400	7900	7550	7500	7500	7450	7450	7200	6950	6750	6550	6350	6200	6000	5850	5700	5500	5400	5300	5200	5100	5050	4950				
		(4.3)	(4.8)	15	24	30	35	39	42	45	48	50	52	53	55	56	58	59	60	61	62	63	64	65				
6.0				7000	6250	6000	6000	5950	5950	5950	5850	5650	5450	5300	5200	5050	4950	4800	4750	4700	4600	4550	4450	4400	4300	4250		
				(5.3)	(5.8)	14	23	29	34	37	40	43	46	48	50	51	53	54	56	57	58	59	60	61	62	63		
7.0					5650	5100	4900	4900	4900	4850	4850	4800	4650	4550	4400	4300	4200	4150	4100	4050	4000	3950	3900	3850	3800			
					(6.3)	(6.8)	14	22	28	32	36	39	41	44	46	48	50	51	53	54	55	56	57	58	59			
8.0							4650	4250	4100	4100	4050	4050	4050	4000	3900	3800	3700	3650	3600	3600	3550	3500	3500	3450	3400			
							(7.3)	(7.8)	13	21	27	31	34	37	40	42	44	46	48	49	51	52	53	55	56			
9.0									3900	3550	3450	3450	3450	3400	3400	3400	3300	3250	3200	3200	3150	3150	3100	3100	3050			
									(8.3)	(8.8)	12	20	25	30	33	36	39	41	43	45	46	48	49	51	52			
10											3300	3050	2950	2950	2900	2900	2900	2950	2900	2850	2850	2800	2800	2750	2750			
											(9.3)	(9.8)	12	19	25	29	32	35	37	40	42	43	45	47	48			
11														2800	2600	2500	2500	2500	2550	2600	2600	2550	2550	2500	2500			
														(10.3)	(10.8)	12	19	24	28	31	34	36	38	40	42	44		
12																2400	2250	2150	2200	2250	2300	2350	2300	2300	2250			
																(11.3)	(11.8)	12	18	23	27	30	33	35	37	40		
13																		2050	1950	1950	2000	2000	2050	2050	2100	2050		
																	(12.3)	(12.8)	11	18	22	26	29	32	35			
14																			1850	1800	1750	1800	1800	1850	1900			
																			(13.3)	(13.8)	11	17	22	25	29			
15																						1700	1600	1600	1650	1650		
																						(14.3)	(14.8)	10	17	22		
16.45																								1550	1500	1400		
																								(15.3)	(15.8)	(16.5)		

MAC-25 3m FLYJIB TOP POSITION AT 0 DEG OFFSET LOAD CHART

COUNTERWEIGHT ON REAR OF CRANE - SPRING LOCKOUTS ENGAGED

LMI DUTY

205

PIVOT TO FLY JIB MAX LENGTH 21.4m	
MAX RADIUS	SWL
6.10	1500
	65
7.76	1500
	60
9.34	1200
	55
10.83	1200
	50
12.22	970
	45
13.49	970
	40
14.65	850
	35
15.67	850
	30
16.55	770
	25
17.29	770
	20
17.88	750
	15
18.31	750
	10
18.58	750
	5
18.69	750
	0



S.W.L IN KILOGRAMS FOR SLEW ANGLES UP TO 40

DEGREES EITHER SIDE OF STRAIGHT AHEAD (INDICATED BY RED LED ON DASH).



BOOM ANGLE - UNDEFLECTED (REF.)

NOTE : VALUES IN BRACKETS () ARE ACTUAL RADIUS AT ZERO DEG. BOOM ANGLE.
SWL IS AT THIS RADIUS

SPRING LOCKOUTS ARE TO BE ENGAGED FOR ALL LIFTING OPERATIONS

S.W.L. ARE BASED ON 66.6% STABILITY & STRENGTH

ALL FLYJIB S.W.L.'S ARE STRUCTURAL

S.W.L. ARE BASED ON FIRM LEVEL GROUND (1% SLOPE (0.6 DEG) AS PER AS1418.5)

WITH TYRES INFLATED AS PER NOTES

LIFT & CARRY - THE S.W.L. SHALL BE CARRIED WITH THE MINIMUM BOOM LENGTH & AS CLOSE TO THE GROUND AS POSSIBLE AT SPEEDS NOT IN EXCESS OF 0.4 M/SEC (1.44 KM/HR)

FLYJIB S.W.L.'S AND RADII ARE BASED ON FULLY EXTENDED BOOM.

FOR OPERATION WITH THE BOOM PART OR FULLY RETRACTED

THE SWL WILL BE BASED ON THE BOOM ANGLE, NOT THE ACTUAL RADIUS.

**NOTE : WEIGHT OF HOOKS, BLOCKS & OTHER
LOAD HANDLING DEVICES SHALL BE ADDED
TO THE WEIGHT OF THE LOAD**

MAC-25 3m FLYJIB TOP POSITION AT 12.5 DEG OFFSET LOAD CHART

COUNTERWEIGHT ON REAR OF CRANE - SPRING LOCKOUTS ENGAGED

LMI DUTY

206

PIVOT TO FLY JIB MAX LENGTH 21.4m	
MAX RADIUS	SWL
6.60	1300
	65
8.23	1300
	60
9.78	1120
	55
11.24	1120
	50
12.59	920
	45
13.83	920
	40
14.94	820
	35
15.92	820
	30
16.76	770
	25
17.45	770
	20
17.99	750
	15
18.37	750
	10
18.59	750
	5
18.65	750
	0



S.W.L IN KILOGRAMS FOR SLEW ANGLES UP TO 40 DEGREES EITHER SIDE OF STRAIGHT AHEAD (INDICATED BY RED LED ON DASH).



BOOM ANGLE - UNDEFLECTED (REF.)

NOTE : VALUES IN BRACKETS () ARE ACTUAL RADIUS AT ZERO DEG. BOOM ANGLE.

SWL IS AT THIS RADIUS

SPRING LOCKOUTS ARE TO BE ENGAGED FOR ALL LIFTING OPERATIONS

S.W.L. ARE BASED ON 66.6% STABILITY & STRENGTH

ALL FLYJIB S.W.L.'S ARE STRUCTURAL

S.W.L. ARE BASED ON FIRM LEVEL GROUND (1% SLOPE (0.6 DEG) AS PER AS1418.5)

WITH TYRES INFLATED AS PER NOTES

LIFT & CARRY - THE S.W.L. SHALL BE CARRIED WITH THE MINIMUM BOOM LENGTH & AS

CLOSE TO THE GROUND AS POSSIBLE AT SPEEDS NOT IN EXCESS OF 0.4 M/SEC (1.44 KM/HR)

FLYJIB S.W.L.'S AND RADII ARE BASED ON FULLY EXTENDED BOOM.

FOR OPERATION WITH THE BOOM PART OR FULLY RETRACTED

THE SWL WILL BE BASED ON THE BOOM ANGLE, NOT THE ACTUAL RADIUS.

**NOTE : WEIGHT OF HOOKS, BLOCKS & OTHER
LOAD HANDLING DEVICES SHALL BE ADDED
TO THE WEIGHT OF THE LOAD**

MAC-25 4m FLYJIB TOP POSITION AT 5 DEG OFFSET LOAD CHART

COUNTERWEIGHT ON REAR OF CRANE - SPRING LOCKOUTS ENGAGED

LMI DUTY

207

PIVOT TO FLY JIB MAX LENGTH 22.48m	
MAX RADIUS	SWL
6.85	700
	65
8.58	600
	60
10.23	600
	55
11.77	600
	50
13.21	600
	45
14.53	500
	40
15.72	500
	35
16.77	500
	30
17.67	500
	25
18.42	500
	20
19.00	500
	15
19.43	500
	10
19.68	500
	5
19.77	500
	0



S.W.L IN KILOGRAMS FOR SLEW ANGLES UP TO 40

DEGREES EITHER SIDE OF STRAIGHT AHEAD (INDICATED BY RED LED ON DASH).



BOOM ANGLE - UNDEFLECTED (REF.)

NOTE : VALUES IN BRACKETS () ARE ACTUAL RADIUS AT ZERO DEG. BOOM ANGLE.
SWL IS AT THIS RADIUS

SPRING LOCKOUTS ARE TO BE ENGAGED FOR ALL LIFTING OPERATIONS

S.W.L. ARE BASED ON 66.6% STABILITY & STRENGTH

ALL FLYJIB S.W.L.'S ARE STRUCTURAL

S.W.L. ARE BASED ON FIRM LEVEL GROUND (1% SLOPE (0.6 DEG) AS PER AS1418.5)

WITH TYRES INFLATED AS PER NOTES

LIFT & CARRY - THE S.W.L. SHALL BE CARRIED WITH THE MINIMUM BOOM LENGTH & AS

CLOSE TO THE GROUND AS POSSIBLE AT SPEEDS NOT IN EXCESS OF 0.4 M/SEC (1.44 KM/HR)

FLYJIB S.W.L.'S AND RADII ARE BASED ON FULLY EXTENDED BOOM.

FOR OPERATION WITH THE BOOM PART OR FULLY RETRACTED

THE SWL WILL BE BASED ON THE BOOM ANGLE, NOT THE ACTUAL RADIUS.

**NOTE : WEIGHT OF HOOKS, BLOCKS & OTHER
LOAD HANDLING DEVICES SHALL BE ADDED
TO THE WEIGHT OF THE LOAD**

MAC-25 4m FLYJIB BOTTOM POSITION AT 17.5 DEG OFFSET LOAD CHART

COUNTERWEIGHT ON REAR OF CRANE - SPRING LOCKOUTS ENGAGED

LMI DUTY

208

PIVOT TO FLY JIB MAX LENGTH 22.41m	
MAX RADIUS	SWL
7.82	600
	65
9.50	600
	60
11.09	600
	55
12.57	500
	50
13.94	500
	45
15.18	500
	40
16.29	500
	35
17.25	500
	30
18.07	500
	25
18.72	500
	20
19.22	500
	15
19.55	500
	10
19.70	500
	5
19.70	500
	0



S.W.L IN KILOGRAMS FOR SLEW ANGLES UP TO 40

DEGREES EITHER SIDE OF STRAIGHT AHEAD (INDICATED BY RED LED ON DASH).



BOOM ANGLE - UNDEFLECTED (REF.)

NOTE : VALUES IN BRACKETS () ARE ACTUAL RADIUS AT ZERO DEG. BOOM ANGLE.
SWL IS AT THIS RADIUS

SPRING LOCKOUTS ARE TO BE ENGAGED FOR ALL LIFTING OPERATIONS

S.W.L. ARE BASED ON 66.6% STABILITY & STRENGTH

ALL FLYJIB S.W.L.'S ARE STRUCTURAL

S.W.L. ARE BASED ON FIRM LEVEL GROUND (1% SLOPE (0.6 DEG) AS PER AS1418.5)

WITH TYRES INFLATED AS PER NOTES

LIFT & CARRY - THE S.W.L. SHALL BE CARRIED WITH THE MINIMUM BOOM LENGTH & AS

CLOSE TO THE GROUND AS POSSIBLE AT SPEEDS NOT IN EXCESS OF 0.4 M/SEC (1.44 KM/HR)

FLYJIB S.W.L.'S AND RADII ARE BASED ON FULLY EXTENDED BOOM.

FOR OPERATION WITH THE BOOM PART OR FULLY RETRACTED

THE SWL WILL BE BASED ON THE BOOM ANGLE, NOT THE ACTUAL RADIUS.

NOTE : WEIGHT OF HOOKS, BLOCKS & OTHER
LOAD HANDLING DEVICES SHALL BE ADDED
TO THE WEIGHT OF THE LOAD

MAC-25 MAN BASKET LOAD CHART

COUNTERWEIGHT ON REAR OF CRANE - SPRING LOCKOUTS ENGAGED

LMI DUTY

209

**MAXIMUM MANBASKET SWL: 275 KG (SEE NOTE BELOW)
BASKET WEIGHT: 225 KG**

*Read and understand warning notes before
operating crane*

**NOTE: THE TOTAL WEIGHT OF THE MANBASKET PLUS
MEN AND EQUIPMENT IS NOT TO EXCEED 1/3 OF
THE SAFE WORKING LOAD AS READ ON LOAD
CHART (FALL BLOCK LOAD CHART - DUTY 201)
FOR THE BOOM LENGTH AND RADIUS BEING USED.**

MAC-25 BUTT LUG - 10 DEG. ART.

COUNTERWEIGHT ON REAR OF CRANE - SPRING LOCKOUTS ENGAGED



S.W.L IN KILOGRAMS FOR SLEW ANGLES OF 10 DEGREES OR LESS EITHER SIDE OF STRAIGHT AHEAD (INDICATED BY GREEN LED ON DASH).



BOOM ANGLE - UNDEFLECTED (REF.)

NOTE: VALUES IN BRACKETS () ARE ACTUAL RADIUS AT ZERO DEG. BOOM ANGLE. SWL IS AT THIS RADIUS

MAC-25 BUTT LUG - 40 DEG. ART.

COUNTERWEIGHT ON REAR OF CRANE - SPRING LOCKOUTS ENGAGED



S.W.L IN KILOGRAMS FOR SLEW ANGLES OF GREATER THAN 10 DEGREES UP TO 40 DEGREES EITHER SIDE OF STRAIGHT AHEAD (INDICATED BY RED LED ON DASH).



BOOM ANGLE - UNDEFLECTED (REF.)

NOTE: VALUES IN BRACKETS () ARE ACTUAL RADIUS AT ZERO DEG. BOOM ANGLE. SWL IS AT THIS RADIUS

S.W.L. ARE BASED ON 66.7% STABILITY & STRENGTH - S.W.L. ABOVE BOLD RED LINE ARE STRUCTURAL
S.W.L. ARE BASED ON FIRM, LEVEL GROUND (1% SLOPE (0.6 DEG) AS PER AS1418.5) WITH TYRES INFLATED AS PER NOTES

LIFT & CARRY - THE S.W.L. SHALL BE CARRIED WITH THE MINIMUM BOOM LENGTH & AS CLOSE TO THE GROUND AS POSSIBLE AT SPEEDS NOT IN EXCESS OF 0.4 M/SEC (1.44 KM/HR)

NOTE: WEIGHT OF HOOKS, BLOCKS & OTHER LOAD HANDLING DEVICES SHALL BE ADDED TO THE WEIGHT OF THE LOAD

Radius in Metres	Boom Length (metres)
	4.81
1.4	25000
	32
1.5	24650
	30
1.6	24200
	27
1.7	23800
	24
1.8	23350
	21
1.9	22950
	18
2.1	20950
	0

NOTE : WEIGHT OF HOOKS, BLOCKS & OTHER LOAD HANDLING DEVICES SHALL BE ADDED TO THE WEIGHT OF THE LOAD

Radius in Metres	Boom Length (metres)
	4.81
1.4	25000
	32
1.5	24650
	30
1.6	24200
	27
1.7	23600
	24
1.8	22200
	21
1.9	20900
	18
2.1	18650
	0

MAC25 LUG 1 LOAD CHART - 10 DEG. ART.

COUNTERWEIGHT ON REAR OF CRANE - SPRING LOCKOUTS ENGAGED

- S.W.L IN KILOGRAMS FOR SLEW ANGLES OF 10 DEGREES OR LESS EITHER SIDE OF STRAIGHT AHEAD (INDICATED BY GREEN LED ON DASH).
- BOOM ANGLE - UNDEFLECTED (REF.)

NOTE: VALUES IN BRACKETS () ARE ACTUAL RADIUS AT ZERO DEG. BOOM ANGLE SWL IS AT THIS RADIUS

MAC25 LUG 1 LOAD CHART - 40 DEG. ART.

COUNTERWEIGHT ON REAR OF CRANE - SPRING LOCKOUTS ENGAGED

- S.W.L IN KILOGRAMS FOR SLEW ANGLES OF GREATER THAN 10 DEGREES UP TO 40 DEGREES EITHER SIDE OF STRAIGHT AHEAD (INDICATED BY RED LED ON DASH).
- BOOM ANGLE - UNDEFLECTED (REF.)

NOTE: VALUES IN BRACKETS () ARE ACTUAL RADIUS AT ZERO DEG. BOOM ANGLE SWL IS AT THIS RADIUS

S.W.L. ARE BASED ON 66.7% STABILITY & STRENGTH - S.W.L. ABOVE BOLD RED LINE ARE STRUCTURAL

S.W.L. ARE BASED ON FIRM, LEVEL GROUND (1% SLOPE (0.6 DEG) AS PER AS1418.5) WITH TYRES INFLATED AS PER NOTES

LIFT & CARRY - THE S.W.L. SHALL BE CARRIED WITH THE MINIMUM BOOM LENGTH & AS CLOSE TO THE GROUND AS POSSIBLE AT SPEEDS NOT IN EXCESS OF 0.4 M/SEC (1.44 KM/HR)

NOTE : WEIGHT OF HOOKS, BLOCKS & OTHER LOAD HANDLING DEVICES SHALL BE ADDED TO THE WEIGHT OF THE LOAD

RADIUS IN METRES	BOOM PIVOT TO LUG 1, 1st EXTENSION, THIRD EXTENSION RETRACTED (metres)									
	5.36	5.50	6.00	6.50	7.00	7.50	8.00	8.50	9.00	9.46
1.4	25000	25000	25000	25000	25000	25000	25000	24800	24650	24000
	40	42	47	51	54	57	59	61	63	64
2	22650	22550	22250	21950	21750	21500	21350	21150	21000	20900
	29	31	38	44	48	51	54	56	59	60
2.5	17750	17700	17450	17200	17000	16800	16650	16500	16400	16300
	14	19	30	37	42	46	49	52	55	57
3	16600	15600	14200	14000	13850	13700	13550	13400	13300	13200
	(2.7)	(2.8)	18	29	35	41	45	48	51	53
3.5			12700	11750	11600	11450	11300	11200	11100	11000
			(3.3)	17	28	34	39	43	46	49
4				10550	9850	9750	9600	9500	9400	9350
				(3.8)	17	27	33	38	42	45
5					8950	7650	7250	7150	7100	7000
					(4.3)	(4.8)	16	25	31	36
6							6600	5750	5500	5450
							(5.3)	(5.8)	15	23
6.8									5000	4450
									(6.3)	(6.8)

RADIUS IN METRES	BOOM PIVOT TO LUG 1, 1st EXTENSION, THIRD EXTENSION RETRACTED (metres)									
	5.36	5.50	6.00	6.50	7.00	7.50	8.00	8.50	9.00	9.46
1.4	25000	24900	19800	17850	16350	15100	14100	13200	12400	11800
	40	42	47	51	54	57	59	61	63	64
2	20250	20150	19500	17800	15200	13900	12850	11950	11200	10600
	29	31	38	44	48	51	54	56	59	60
2.5	15800	15750	15500	15250	14600	13550	12700	11050	10300	9750
	14	19	30	37	42	46	49	52	55	57
3	14750	13850	12600	12400	12200	12050	11300	10650	10050	8950
	(2.7)	(2.8)	18	29	35	41	45	48	51	53
3.5			11200	10350	10200	10050	9900	9550	9000	8550
			(3.3)	17	28	34	39	43	46	49
4				9300	8650	8550	8400	8300	8100	7700
				(3.8)	17	27	33	38	42	45
5					7800	6650	6300	6200	6100	6050
					(4.3)	(4.8)	16	25	31	36
6							5700	4900	4700	4650
							(5.3)	(5.8)	15	23
6.8									4250	3750
									(6.3)	(6.8)

**THIS PAGE HAS BEEN
INTENTIONALLY LEFT BLANK**

MAC-25 LUG 2 LOAD CHART - 10 DEG. ART.

LMI DUTY

212

COUNTERWEIGHT ON REAR OF CRANE - SPRING LOCKOUTS ENGAGED



S.W.L IN KILOGRAMS FOR SLEW ANGLES OF 10 DEGREES OR LESS EITHER

S.W.L. ARE BASED ON 66.7% STABILITY & STRENGTH

SIDE OF STRAIGHT AHEAD (INDICATED BY GREEN LED ON DASH).

- S.W.L. ABOVE BOLD RED LINE ARE STRUCTURAL



BOOM ANGLE - UNDEFLECTED (REF.)

S.W.L. ARE BASED ON FIRM LEVEL GROUND (1% SLOPE (0.6 DEG) AS

NOTE: VALUES IN BRACKETS () ARE ACTUAL RADIUS AT ZERO DEG. BOOM ANGLE.

PER AS1418.5) WITH TYRES INFLATED AS PER NOTES

ENSURE WINCH ROPE IS FULLY TENSIONED

LIFT & CARRY - THE S.W.L. SHALL BE CARRIED WITH THE MIN BOOM LENGTH & AS CLOSE TO THE GROUND AS POSSIBLE AT SPEEDS NOT IN EXCESS OF 0.4 M/SEC (1.44 KM/HR)

Radius in Metres	BOOM PIVOT TO LUG 2, 2nd EXTENSION, THIRD EXTENSION RETRACTED (metres)																	
	5.57	6.00	6.50	7.00	7.50	8.00	8.50	9.00	9.50	10.00	10.50	11.00	11.50	12.00	12.50	13.00	13.50	13.77
1.4	25000	25000	25000	25000	25000	25000	25000	25000	25000									
	42	46	50	54	57	59	61	63	64									
2	22800	22750	22750	22700	22700	22650	22650	22600	22600	22550	21850	19400						
	32	38	43	47	51	54	56	58	60	62	63	64						
2.5	17900	17900	17900	17850	17850	17850	17800	17800	17800	17750	17750	17700	16550	15650				
	20	29	36	42	46	49	52	54	57	58	60	62	63	64				
3	15350	14650	14650	14650	14600	14600	14600	14600	14550	14550	14550	14550	14500	14400	13600	12900		
	(2.9)	18	28	35	40	44	48	50	53	55	57	59	60	61	63	64		
3.5		13150	12300	12300	12300	12300	12300	12300	12250	12250	12250	12250	12250	12200	12200	11900	11250	10900
		(3.3)	17	27	34	39	43	46	49	51	54	55	57	59	60	61	62	63
4			11200	10550	10600	10550	10550	10550	10550	10550	10550	10500	10500	10500	10500	10500	10450	10150
			(3.8)	16	26	33	38	42	45	48	50	52	54	56	57	59	60	61
5				9650	8500	8150	8150	8150	8150	8100	8100	8100	8100	8100	8100	8100	8100	8050
				(4.3)	(4.8)	15	25	31	36	39	43	45	48	50	52	53	55	56
6					7500	6700	6500	6500	6500	6500	6500	6500	6500	6500	6500	6500	6450	6450
					(5.3)	(5.8)	14	23	29	34	37	41	43	46	48	50	51	
7							6050	5500	5350	5350	5350	5350	5350	5350	5350	5350	5350	5350
							(6.3)	(6.8)	14	22	28	32	36	39	42	44	45	
8									5000	4550	4450	4450	4450	4450	4450	4450	4450	4450
									(7.3)	(7.8)	13	21	27	31	34	37	39	
9												4200	3850	3800	3800	3800	3800	3800
												(8.3)	(8.8)	12	20	26	30	32
10														3550	3300	3250	3250	3250
														(9.3)	(9.8)	12	19	23
11																3050	2800	2800
																(10.3)	(10.8)	6
11.1																		2700
																		(11.1)

MAC-25 LUG 2 LOAD CHART - 40 DEG. ART.

LMI DUTY

212

COUNTERWEIGHT ON REAR OF CRANE - SPRING LOCKOUTS ENGAGED



S.W.L IN KILOGRAMS FOR SLEW ANGLES OF GREATER THAN 10 DEGREES UP TO 40 DEGREES EITHER SIDE OF STRAIGHT AHEAD (INDICATED BY RED LED ON DASH).



BOOM ANGLE - UNDEFLECTED (REF.)

S.W.L. ARE BASED ON 66.7% STABILITY & STRENGTH

- S.W.L. ABOVE BOLD RED LINE ARE STRUCTURAL

S.W.L. ARE BASED ON FIRM LEVEL GROUND (1% SLOPE (0.6 DEG)

AS PER AS1418.5) WITH TYRES INFLATED AS PER NOTES

NOTE: VALUES IN BRACKETS () ARE ACTUAL RADIUS AT ZERO DEG. BOOM ANGLE.

ENSURE WINCH ROPE IS FULLY TENSIONED

LIFT & CARRY - THE S.W.L. SHALL BE CARRIED WITH THE MIN BOOM LENGTH & AS CLOSE TO THE GROUND AS POSSIBLE AT SPEEDS NOT IN EXCESS OF 0.4 M/SEC (1.44 KM/HR)

Radius in Metres	BOOM PIVOT TO LUG 2, 2nd EXTENSION, THIRD EXTENSION RETRACTED (METRES)																			
	(metres)																			
	5.57	6.00	6.50	7.00	7.50	8.00	8.50	9.00	9.50	10.00	10.50	11.00	11.50	12.00	12.50	13.00	13.50	13.77		
1.4	22150	20050	18300	16900	15750	14800	14000	13300	12650											
	42	46	50	54	57	59	61	63	64											
2	20350	19900	18400	15800	14600	13650	12850	12150	11550	11050	10550	10100								
	32	38	43	47	51	54	56	58	60	62	63	64								
2.5	15950	15950	15950	15350	14450	13700	11950	11300	10750	10250	9800	9400	9000	8700						
	20	29	36	42	46	49	52	54	57	58	60	62	63	64						
3	13650	13000	13050	13000	13000	12300	11700	11200	10000	9500	9100	8700	8350	8050	7800	7500				
	(2.9)	18	28	35	40	44	48	50	53	55	57	59	60	61	63	64				
3.5		11650	10950	10950	10950	10900	10600	10100	9700	8850	8450	8100	7750	7500	7250	7000	6750	6650		
		(3.3)	17	27	34	39	43	46	49	51	54	55	57	59	60	61	62	63		
4			9900	9350	9350	9350	9350	9250	8850	8500	8200	7550	7250	6950	6750	6500	6300	6200		
			(3.8)	16	26	33	38	42	45	48	50	52	54	56	57	59	60	61		
5				8550	7450	7150	7150	7150	7150	6950	6700	6500	6300	6150	5650	5500	5400			
				(4.3)	(4.8)	15	25	31	36	39	43	45	48	50	52	53	55	56		
6					6600	5900	5700	5700	5700	5700	5700	5600	5400	5250	5100	5000	4900			
					(5.3)	(5.8)	14	23	29	34	37	41	43	46	48	50	51			
7							5300	4750	4650	4650	4650	4650	4650	4600	4450	4350	4300			
							(6.3)	(6.8)	14	22	28	32	36	39	42	44	45			
8									4300	3950	3850	3850	3850	3850	3850	3800	3750			
									(7.3)	(7.8)	13	21	27	31	34	37	39			
9											3600	3300	3250	3250	3250	3250	3250			
											(8.3)	(8.8)	12	20	26	30	32			
10		NOTE : WEIGHT OF HOOKS, BLOCKS & OTHER LOAD HANDLING DEVICES SHALL BE ADDED TO THE WEIGHT OF THE LOAD												3000	2800	2750	2750	2750		
														(9.3)	(9.8)	12	19	23		
11																2550	2350	2350		
																(10.3)	(10.8)	6		
11.1																		2250		
																			(11.1)	

MAC-25 FALL BLOCK LOAD CHART - 10 DEG. ART.

LMI DUTY

301

STANDARD 1500 KG COUNTERWEIGHT (PLMXF2009) + EXTRA 2160 KG COUNTERWEIGHT (PLMXF2019-) ON REAR OF CRANE - SPRING LOCKOUTS ENGAGED



RC IN KILOGRAMS FOR SLEW ANGLES OF 10 DEGREES OR LESS EITHER SIDE OF STRAIGHT AHEAD (INDICATED BY GREEN LED ON DASH).



BOOM ANGLE - UNDEFLECTED (REF.)

NOTE: VALUES IN BRACKETS () ARE ACTUAL RADIUS AT ZERO DEG. BOOM ANGLE.

RC ARE BASED ON 66.6% STABILITY & STRENGTH

RC ABOVE BOLD RED LINE ARE STRUCTURAL

RC ARE BASED ON FIRM LEVEL GROUND (1% SLOPE (0.6 DEG) AS PER AS1418.5) WITH TYRES INFLATED AS PER NOTES

LIFT & CARRY - THE RC SHALL BE CARRIED WITH THE MINIMUM BOOM LENGTH & AS CLOSE TO THE GROUND AS POSSIBLE AT SPEEDS NOT IN EXCESS OF 0.4 m/s (1.44 km/h)

Radius in Metres	BOOM PIVOT TO HEAD SHEAVES - THIRD BOOM RETRACTED (metres)														THIRD BOOM EXTENDING (metres)												
	6.12	6.50	7.00	7.50	8.00	8.50	9.00	9.50	10.00	10.50	11.00	11.50	12.00	12.50	13.00	13.50	14.32	14.50	15.00	15.50	16.00	16.50	17.00	17.50	18.00	18.42	
1.4	25000	25000	25000	25000	25000	25000	25000	25000																			
	48	51	54	57	59	61	63	65																			
2.0	23400	23400	23250	23350	23350	23300	23300	23300	23250	22150	19300																
	40	44	48	51	54	57	59	61	62	64	65																
2.5	21450	21400	21350	21350	21300	21250	21200	21200	20450	17750	15550	14600															
	32	37	42	46	50	52	55	57	59	61	62	63	65														
3.0	17600	17600	17600	17550	17500	17500	17450	17450	17400	17400	16500	14350	13500	13000	12600	12250											
	21	29	35	41	45	48	51	53	55	57	59	61	62	63	64	65											
3.5	15250	14850	14850	14850	14800	14800	14750	14750	14700	14700	14700	13350	12600	12150	11750	11400	10850	10750									
	(3.4)	17	28	34	39	43	47	49	52	54	56	58	59	61	62	63	65	65									
4.0		13600	12800	12800	12800	12750	12750	12750	12700	12700	12700	12550	11750	11350	10950	10600	10100	10050	9850	9650							
		(3.8)	17	27	33	38	42	45	48	51	53	55	56	58	59	61	62	63	64	65							
5.0			11800	10400	9900	9900	9900	9900	9900	9850	9850	9850	9850	9800	9650	9350	8900	8800	8650	8500	8400	8250	8150	8000	7900		
			(4.3)	(4.8)	16	25	31	36	40	43	46	48	50	52	54	56	58	58	59	61	62	63	63	64	65		
6.0					9250	8300	8000	8000	8000	8000	7950	7950	7950	7950	7950	7900	7900	7900	7900	7750	7600	7450	7350	7200	7100	7000	6950
					(5.3)	(5.8)	15	24	30	34	38	41	44	46	48	50	53	53	55	56	57	58	60	61	61	62	
7.0							7500	6850	6600	6600	6600	6600	6600	6600	6600	6600	6550	6600	6600	6650	6700	6600	6500	6400	6300	6250	
							(6.3)	(6.8)	14	23	28	33	36	39	42	44	48	48	50	52	53	54	56	57	58	59	
8.0										6250	5750	5600	5600	5600	5600	5550	5550	5550	5550	5600	5650	5700	5700	5750	5800	5700	5650
										(7.3)	(7.8)	13	22	27	31	35	38	42	43	45	47	48	50	51	53	54	55
9.0												5300	4900	4800	4800	4800	4800	4750	4800	4850	4850	4900	4950	4950	5000	5000	5050
												(8.3)	(8.8)	13	21	26	30	35	36	39	41	43	45	47	48	50	51
10														4550	4250	4150	4150	4150	4150	4200	4250	4250	4300	4350	4400	4400	
														(9.3)	(9.8)	12	20	28	29	32	35	38	40	42	44	45	47
11																3950	3700	3600	3650	3700	3700	3750	3800	3800	3850	3850	3900
																(10.3)	(10.8)	17	19	24	28	31	34	37	39	41	42
12																		3350	3250	3250	3300	3300	3350	3400	3400	3450	3450
																		(11.6)	(11.8)	12	19	23	27	30	33	36	37
13																				3100	2950	2950	3000	3000	3050	3050	3100
																				(12.3)	(12.8)	11	18	23	27	30	32
14																						2850	2700	2700	2700	2750	2750
																						(13.3)	(13.8)	11	18	22	25
15																								2600	2500	2450	2500
																								(14.3)	(14.8)	10	16
15.71																										2400	2300
																										(15.3)	(15.7)

MAC-25 FALL BLOCK LOAD CHART - 40 DEG. ART.

LMI DUTY

301

STANDARD 1500 KG COUNTERWEIGHT (PLMXF2009) + EXTRA 2160 KG COUNTERWEIGHT (PLMXF2019-) ON REAR OF CRANE - SPRING LOCKOUTS ENGAGED



RC IN KILOGRAMS FOR SLEW ANGLES OF GREATER THAN 10 DEGREES UP TO 40 DEGREES EITHER SIDE OF STRAIGHT AHEAD (INDICATED BY RED LED ON DASH).



BOOM ANGLE - UNDEFLECTED (REF.)

NOTE : VALUES IN BRACKETS () ARE ACTUAL RADIUS AT ZERO DEG. BOOM ANGLE.
RC ARE BASED ON 66.6% STABILITY & STRENGTH

RC ABOVE BOLD RED LINE ARE STRUCTURAL

RC ARE BASED ON FIRM LEVEL GROUND (1% SLOPE (0.6 DEG) AS PER AS1418.5)

WITH TYRES INFLATED AS PER NOTES

LIFT & CARRY - THE RC SHALL BE CARRIED WITH THE MINIMUM BOOM LENGTH & AS CLOSE TO THE GROUND AS POSSIBLE AT SPEEDS NOT IN EXCESS OF 0.4 m/s (1.44 km/h)

Radius in Metres	BOOM PIVOT TO HEAD SHEAVES - THIRD BOOM RETRACTED (metres)														THIRD BOOM EXTENDING (metres)													
	6.12	6.50	7.00	7.50	8.00	8.50	9.00	9.50	10.00	10.50	11.00	11.50	12.00	12.50	13.00	13.50	14.32	14.50	15.00	15.50	16.00	16.50	17.00	17.50	18.00	18.42		
1.4	21000	19600	18100	16900	15900	15000	14250	13600																				
	48	51	54	57	59	61	63	65																				
2.0	20650	18850	17150	15850	14800	13900	13200	12550	11950	11450	11000																	
	40	44	48	51	54	57	59	61	62	64	65																	
2.5	18900	17700	16450	15050	13950	13100	12350	11700	11150	10700	10250	9850	9500															
	32	37	42	46	50	52	55	57	59	61	62	63	65															
3.0	15700	15700	15000	14000	13200	12300	11600	11000	10450	10000	9550	9200	8850	8250	8000													
	21	29	35	41	45	48	51	53	55	57	59	61	62	63	64	65												
3.5	13600	13250	13200	12850	12100	11500	10900	10300	9800	9350	8950	8600	8300	8000	7700	7500	7100	7050										
	(3.4)	17	28	34	39	43	47	49	52	54	56	58	59	61	62	63	65	65										
4.0		12050	11350	11350	11150	10550	10050	9650	9150	8750	8400	8050	7750	7500	7250	7000	6650	6600	6450	6350								
		(3.8)	17	27	33	38	42	45	48	51	53	55	56	58	59	61	62	63	64	65								
5.0			10450	9200	8750	8750	8700	8250	7900	7650	7350	7100	6800	6600	6350	6150	5850	5800	5700	5600	5500	5400	5300	5200	5100			
			(4.3)	(4.8)	16	25	31	36	40	43	46	48	50	52	54	56	58	58	59	61	62	63	63	64	65			
6.0					8200	7350	7050	7050	6950	6650	6400	6200	6000	5850	5650	5450	5200	5150	5050	4950	4900	4800	4700	4650	4600	4500		
					(5.3)	(5.8)	15	24	30	34	38	41	44	46	48	50	53	53	55	56	57	58	60	61	61	62		
7.0							6600	6000	5800	5800	5700	5500	5300	5150	5000	4850	4650	4600	4500	4450	4350	4300	4250	4150	4100	4050		
							(6.3)	(6.8)	14	23	28	33	36	39	42	44	48	48	50	52	53	54	56	57	58	59		
8.0									5500	5050	4850	4850	4750	4600	4450	4300	4150	4100	4050	4000	3950	3900	3800	3750	3700	3700		
									(7.3)	(7.8)	13	22	27	31	35	38	42	43	45	47	48	50	51	53	54	55		
9.0											4650	4250	4150	4150	4050	3900	3700	3700	3650	3600	3550	3500	3450	3400	3350	3350		
											(8.3)	(8.8)	13	21	26	30	35	36	39	41	43	45	47	48	50	51		
10													3950	3650	3550	3550	3350	3350	3300	3250	3200	3200	3150	3100	3100	3050		
													(9.3)	(9.8)	12	20	28	29	32	35	38	40	42	44	45	47		
11															3400	3200	3100	3100	3050	2950	2950	2900	2850	2850	2800	2800		
															(10.3)	(10.8)	17	19	24	28	31	34	37	39	41	42		
12																	2850	2800	2750	2800	2700	2650	2650	2600	2550	2550		
																	(11.6)	(11.8)	12	19	23	27	30	33	36	37		
13																			2650	2500	2500	2500	2450	2400	2400	2350		
																			(12.3)	(12.8)	11	18	23	27	30	32		
14																					2400	2300	2300	2250	2200	2200		
																					(13.3)	(13.8)	11	18	22	25		
15																							2200	2100	2100	2100		
																							(14.3)	(14.8)	10	16		
15.71																									2000	1950		
																									(15.3)	(15.7)		

WINCH RC
SINGLE PART 4200
TWO PARTS 8400
FOUR PARTS 16800
SIX PARTS 25000

NOTE : WEIGHT OF HOOKS, BLOCKS & OTHER LOAD HANDLING DEVICES SHALL BE ADDED TO THE WEIGHT OF THE LOAD

MAC-25 RHINO HOOK LOAD CHART - 10 DEG

LMI DUTY

302

STANDARD 1500 KG COUNTERWEIGHT (PLMXF2009) + EXTRA 2160 KG COUNTERWEIGHT (PLMXF2019-) ON REAR OF CRANE - SPRING LOCKOUTS ENGAGED

15000 RC IN KILOGRAMS FOR SLEW ANGLES OF 10 DEGREES OR LESS EITHER
 SIDE OF STRAIGHT AHEAD (INDICATED BY GREEN LED ON DASH).
15000 BOOM ANGLE - UNDEFLECTED (REF.)

RC ABOVE BOLD RED LINE ARE STRUCTURAL
 RC ARE BASED ON FIRM LEVEL GROUND (1% SLOPE (0.6 DEG) AS PER AS1418.5)
 WITH TYRES INFLATED AS PER NOTES
 LIFT & CARRY - THE RC SHALL BE CARRIED WITH THE MINIMUM BOOM LENGTH & AS
 CLOSE TO THE GROUND AS POSSIBLE AT SPEEDS NOT IN EXCESS OF 0.4 m/s (1.44 km/h)

NOTE : VALUES IN BRACKETS () ARE ACTUAL RADIUS AT ZERO DEG. BOOM ANGLE.
 RC ARE BASED ON 66.6% STABILITY & STRENGTH

Radius in Metres	BOOM PIVOT TO HOOK CENTRE - THIRD BOOM RETRACTED (metres)														THIRD BOOM EXTENDING (metres)											
	6.45	7.00	7.50	8.00	8.50	9.00	9.50	10.00	10.50	11.00	11.50	12.00	12.50	13.00	13.50	14.00	14.65	15.00	15.50	16.00	16.50	17.00	17.50	18.00	18.50	18.75
1.4	15000	15000	15000	15000	15000	15000	15000																			
	51	55	58	60	62	64	65																			
2.0	15000	15000	15000	15000	15000	15000	15000	15000	15000	15000																
	44	49	52	55	57	59	61	63	64	65																
2.5	15000	15000	15000	15000	15000	15000	15000	15000	15000	15000	15000	14200														
	37	43	47	50	53	56	58	59	61	63	64	65														
3.0	15000	15000	15000	15000	15000	15000	15000	15000	15000	15000	15000	13200	12750	12300												
	29	36	41	45	49	52	54	56	58	60	61	62	64	65												
3.5	15000	15000	15000	14950	14950	14900	14900	14850	14850	14800	14000	12300	11850	11450	11150	10800										
	17	29	35	40	44	47	50	52	55	56	58	60	61	62	63	64										
4.0	13950	12950	12950	12900	12900	12850	12850	12800	12800	12800	12750	11500	11100	10750	10400	10100	9750	9600	9450							
	(3.7)	18	28	34	39	43	46	49	51	53	55	57	58	60	61	62	63	64	65							
5.0		11950	10500	10000	10000	10000	10000	10000	9950	9950	9950	9950	9900	9800	9500	9200	8900	8600	8500	8350	8200	8050	7900	7800	7700	
		(4.3)	(4.8)	16	26	32	37	40	44	46	49	51	53	54	56	57	59	60	61	62	63	64	65	65		
6.0			9350	8400	8100	8100	8050	8050	8050	8050	8000	8000	8000	8000	7950	7650	7550	7400	7300	7200	7050	6950	6850	6800	6650	
			(5.3)	(5.8)	15	24	30	35	38	42	44	47	49	51	52	54	55	57	58	59	60	61	62	63	63	
7.0					7600	6950	6700	6700	6700	6650	6650	6650	6650	6650	6650	6600	6650	6700	6550	6450	6350	6250	6200	6100	6050	
					(6.3)	(6.8)	15	23	29	33	37	40	42	45	47	49	50	52	53	55	56	57	58	59	60	
8.0								6350	5850	5650	5650	5650	5650	5650	5600	5600	5600	5650	5650	5700	5750	5750	5700	5600	5550	5500
								(7.3)	(7.8)	14	22	28	32	35	38	41	44	45	47	49	50	52	53	54	55	56
9.0										5400	5000	4850	4850	4850	4850	4800	4800	4850	4900	4900	4950	4950	5000	5050	5050	5050
										(8.3)	(8.8)	13	21	27	31	34	38	39	42	44	46	47	49	50	51	52
10											4600	4300	4200	4200	4200	4200	4200	4200	4250	4300	4350	4350	4400	4400	4450	
											(9.3)	(9.8)	13	20	26	31	33	36	38	40	42	44	46	47	48	
11														4000	3750	3650	3650	3700	3700	3750	3800	3800	3850	3850	3900	3900
														(10.3)	(10.8)	12	21	25	29	32	35	37	39	41	43	44
12																3500	3250	3250	3300	3300	3350	3400	3400	3450	3450	3450
																(11.3)	(11.9)	12	19	24	28	31	34	36	38	39
13																	3100	2950	2950	3000	3000	3050	3050	3100	3100	
																	(12.3)	(12.8)	12	18	23	27	30	33	34	
14																				2850	2700	2700	2700	2750	2800	2800
																				(13.3)	(13.8)	11	18	23	26	28
15																						2600	2500	2450	2500	2500
																						(14.3)	(14.8)	11	17	20
16																								2400	2300	2250
																								(15.3)	(15.8)	(16.)

NOTE : WEIGHT OF HOOKS, BLOCKS & OTHER
 LOAD HANDLING DEVICES SHALL BE ADDED
 TO THE WEIGHT OF THE LOAD

MAC-25 RHINO HOOK LOAD CHART - 40 DEG

LMI DUTY

302

STANDARD 1500 KG COUNTERWEIGHT (PLMXF2009) + EXTRA 2160 KG COUNTERWEIGHT (PLMXF2019-) ON REAR OF CRANE - SPRING LOCKOUTS ENGAGED

█ RC IN KILOGRAMS FOR SLEW ANGLES OF GREATER THAN 10 DEGREES UP TO 40 DEGREES EITHER SIDE OF STRAIGHT AHEAD (INDICATED BY RED LED ON DASH).
▭ BOOM ANGLE - UNDEFLECTED (REF.)

RC ABOVE BOLD RED LINE ARE STRUCTURAL
 RC ARE BASED ON FIRM LEVEL GROUND (1% SLOPE (0.6 DEG) AS PER AS1418.5) WITH TYRES INFLATED AS PER NOTES
 LIFT & CARRY - THE RC SHALL BE CARRIED WITH THE MINIMUM BOOM LENGTH & AS CLOSE TO THE GROUND AS POSSIBLE AT SPEEDS NOT IN EXCESS OF 0.4 m/s (1.44 km/h)

NOTE : VALUES IN BRACKETS () ARE ACTUAL RADIUS AT ZERO DEG. BOOM ANGLE.
 RC ARE BASED ON 66.6% STABILITY & STRENGTH

Radius in Metres	BOOM PIVOT TO HOOK CENTRE - THIRD BOOM RETRACTED (metres)														THIRD BOOM EXTENDING (metres)														
	6.45	7.00	7.50	8.00	8.50	9.00	9.50	10.00	10.50	11.00	11.50	12.00	12.50	13.00	13.50	14.00	14.65	15.00	15.50	16.00	16.50	17.00	17.50	18.00	18.50	18.75			
1.4	15000	15000	15000	15000	15000	14350	13700																						
2.0	15000	15000	15000	14900	14000	13250	12600	12050	11550	11050																			
2.5	15000	15000	15000	14100	13200	12450	11800	11250	10750	10300	9900	9550																	
3.0	15000	15000	14150	13350	12450	11700	11050	10550	10050	9650	9250	8950	8600	8350															
3.5	13400	13400	13000	12250	11600	11000	10400	9850	9400	9000	8650	8350	8050	7800	7550	7300													
4.0	12400	11500	11500	11300	10650	10150	9750	9250	8850	8450	8100	7800	7550	7300	7050	6850	6600	6500	6350										
5.0		10600	9300	8900	8850	8800	8350	8000	7700	7450	7150	6900	6650	6400	6200	6050	5800	5700	5600	5500	5400	5300	5200	5150					
6.0				8300	7400	7100	7100	7050	6750	6500	6250	6050	5900	5700	5500	5350	5150	5100	5000	4900	4800	4750	4650	4600	4500	4500	4500		
7.0						6700	6100	5850	5850	5750	5550	5350	5200	5050	4900	4750	4600	4550	4450	4400	4300	4250	4200	4100	4050	4050	4050		
8.0											5550	5100	4950	4950	4800	4650	4500	4350	4250	4100	4050	4000	3950	3900	3850	3800	3700	3650	3650
9.0																													
10																													
11																													
12																													
13																													
14																													
15																													
16																													

NOTE : WEIGHT OF HOOKS, BLOCKS & OTHER LOAD HANDLING DEVICES SHALL BE ADDED TO THE WEIGHT OF THE LOAD

MAC-25 OFFSET HEAD BOTTOM POSITION LOAD CHART - 10 DEG

LMI DUTY

303

STANDARD 1500 KG COUNTERWEIGHT (PLMXF2009) + EXTRA 2160 KG COUNTERWEIGHT (PLMXF2019-) ON REAR OF CRANE - SPRING LOCKOUTS ENGAGED

8400 RC IN KILOGRAMS FOR SLEW ANGLES OF 10 DEGREES OR LESS EITHER
SIDE OF STRAIGHT AHEAD (INDICATED BY GREEN LED ON DASH).
8400 BOOM ANGLE - UNDEFLECTED (REF.)

RC ABOVE BOLD RED LINE ARE STRUCTURAL
RC ARE BASED ON FIRM LEVEL GROUND (1% SLOPE (0.6 DEG) AS PER AS1418.5)
WITH TYRES INFLATED AS PER NOTES
LIFT & CARRY - THE RC SHALL BE CARRIED WITH THE MINIMUM BOOM LENGTH & AS
CLOSE TO THE GROUND AS POSSIBLE AT SPEEDS NOT IN EXCESS OF 0.4 m/s (1.44 km/h)

NOTE : VALUES IN BRACKETS () ARE ACTUAL RADIUS AT ZERO DEG. BOOM ANGLE.
RC ARE BASED ON 66.6% STABILITY & STRENGTH

Radius in Metres	BOOM PIVOT TO EDGE OF SHEAVE - THIRD BOOM RETRACTED (metres)															THIRD BOOM EXTENDING (metres)											
	6.86	7.00	7.50	8.00	8.50	9.00	9.50	10.00	10.50	11.00	11.50	12.00	12.50	13.00	13.50	14.00	14.50	15.06	15.50	16.00	16.50	17.00	17.50	18.00	18.50	19.16	
1.4	8400	8400	8400	8400	8400	8400																					
	55	56	59	61	63	65																					
2.0	8400	8400	8400	8400	8400	8400	8400	8400	8400																		
	49	50	53	56	58	60	62	64	65																		
2.5	8400	8400	8400	8400	8400	8400	8400	8400	8400	8400	8400																
	43	44	48	51	54	56	58	60	62	63	65																
3.0	8400	8400	8400	8400	8400	8400	8400	8400	8400	8400	8400	8400	8400														
	36	38	43	46	50	52	55	57	59	60	62	63	64	65													
3.5	8400	8400	8400	8400	8400	8400	8400	8400	8400	8400	8400	8400	8400	8400	8400												
	27	30	36	41	45	48	51	53	55	57	59	60	62	63	64	65											
4.0	8400	8400	8400	8400	8400	8400	8400	8400	8400	8400	8400	8400	8400	8400	8400	8400	8400										
	(4.2)	19	29	35	40	44	47	50	52	54	56	58	59	60	62	63	64	65									
5.0		8400	8400	8400	8400	8400	8400	8400	8400	8400	8400	8400	8400	8400	8400	8400	8400	8400	8400	8350	8250	8100	8000				
		(4.3)	(4.8)	18	27	33	38	41	44	47	49	52	53	55	57	58	59	61	61	62	63	64	65				
6.0				8400	8400	8200	8200	8200	8150	8150	8150	8100	8100	8100	8050	7950	7700	7600	7450	7350	7200	7100	7000	6500	5850		
				(5.3)	(5.8)	17	25	31	36	39	42	45	47	49	51	53	54	56	57	58	59	60	61	62	63	64	
7.0						7700	7050	6800	6800	6800	6750	6750	6750	6750	6700	6700	6700	6700	6700	6700	6600	6500	6400	6300	6100	6050	
						(6.3)	(6.8)	16	24	30	34	37	40	43	45	47	49	51	52	54	55	56	57	59	59	61	
8.0								6450	5900	5750	5750	5700	5700	5700	5700	5700	5700	5650	5700	5750	5750	5800	5800	5700	5650	5150	
								(7.3)	(7.8)	15	23	28	33	36	39	41	44	46	48	49	51	52	53	55	56	57	
9.0										5450	5050	4900	4900	4900	4900	4900	4900	4900	4900	4950	5000	5000	5050	5050	5100	4850	
										(8.3)	(8.8)	14	22	27	31	35	37	40	42	44	46	48	49	51	52	53	
10												4700	4350	4250	4250	4250	4250	4250	4250	4300	4350	4350	4400	4400	4450	4450	
												(9.3)	(9.8)	14	21	26	30	34	36	39	41	43	45	46	48	50	
11															4050	3800	3700	3700	3700	3750	3800	3800	3850	3850	3900	3950	
															(10.3)	(10.8)	13	20	26	29	32	35	37	40	42	45	
12																	3550	3350	3250	3300	3350	3400	3400	3450	3450	3500	3500
																	(11.3)	(11.8)	14	20	24	28	31	34	36	39	41
13																			3100	3000	2950	3000	3050	3050	3100	3150	
																			(12.4)	(12.8)	12	19	24	27	30	33	36
14																					2850	2750	2700	2750	2750	2800	2800
																					(13.3)	(13.8)	12	18	23	27	30
15																						2600	2500	2500	2500	2550	
																						(14.3)	(14.8)	12	18	24	
16.4																								2400	2300	2200	
																								(15.3)	(15.8)	(16.4)	

MAC-25 OFFSET HEAD BOTTOM POSITION LOAD CHART - 40 DEG

LMI DUTY

303

STANDARD 1500 KG COUNTERWEIGHT (PLMXF2009) + EXTRA 2160 KG COUNTERWEIGHT (PLMXF2019-) ON REAR OF CRANE - SPRING LOCKOUTS ENGAGED

8400 RC IN KILOGRAMS FOR SLEW ANGLES OF GREATER THAN 10 DEGREES UP TO 40

RC ABOVE BOLD RED LINE ARE STRUCTURAL

8400 DEGREES EITHER SIDE OF STRAIGHT AHEAD (INDICATED BY RED LED ON DASH).

RC ARE BASED ON FIRM LEVEL GROUND (1% SLOPE (0.6 DEG) AS PER AS1418.5)

8400 BOOM ANGLE - UNDEFLECTED (REF.)

WITH TYRES INFLATED AS PER NOTES

NOTE : VALUES IN BRACKETS () ARE ACTUAL RADIUS AT ZERO DEG. BOOM ANGLE.

LIFT & CARRY - THE RC SHALL BE CARRIED WITH THE MINIMUM BOOM LENGTH & AS

RC ARE BASED ON 66.6% STABILITY & STRENGTH

CLOSE TO THE GROUND AS POSSIBLE AT SPEEDS NOT IN EXCESS OF 0.4 m/s (1.44 km/h)

Radius in Metres	BOOM PIVOT TO EDGE OF SHEAVE - THIRD BOOM RETRACTED (metres)															THIRD BOOM EXTENDING (metres)											
	6.86	7.00	7.50	8.00	8.50	9.00	9.50	10.00	10.50	11.00	11.50	12.00	12.50	13.00	13.50	14.00	14.50	15.06	15.50	16.00	16.50	17.00	17.50	18.00	18.50	19.16	
1.4	8400	8400	8400	8400	8400	8400																					
	55	56	59	61	63	65																					
2.0	8400	8400	8400	8400	8400	8400	8400	8400	8400	8400																	
	49	50	53	56	58	60	62	64	65																		
2.5	8400	8400	8400	8400	8400	8400	8400	8400	8400	8400	8400																
	43	44	48	51	54	56	58	60	62	63	65																
3.0	8400	8400	8400	8400	8400	8400	8400	8400	8400	8400	8400	8400	8400														
	36	38	43	46	50	52	55	57	59	60	62	63	64	65													
3.5	8400	8400	8400	8400	8400	8400	8400	8400	8400	8400	8400	8400	8150	7850	7600	7400											
	27	30	36	41	45	48	51	53	55	57	59	60	62	63	64	65											
4.0	8400	8400	8400	8400	8400	8400	8400	8400	8400	8400	8400	8200	7900	7650	7400	7150	6900	6700	6500								
	(4.2)	19	29	35	40	44	47	50	52	54	56	58	59	60	62	63	64	65									
5.0	8400	8400	8400	8400	8400	8400	8400	8150	7850	7550	7250	7000	6750	6500	6300	6100	5950	5750	5650	5550	5450	5350	5250				
	(4.3)	(4.8)	18	27	33	38	41	44	47	49	52	53	55	57	58	59	61	61	62	63	64	65					
6.0	8400	8400	8400	8400	7500	7250	7250	7150	6850	6600	6350	6150	6000	5750	5600	5400	5250	5100	5000	4950	4850	4750	4700	4600	4550	4450	
			(5.3)	(5.8)	17	25	31	36	39	42	45	47	49	51	53	54	56	57	58	59	60	61	62	63	64		
7.0					6800	6200	5950	5950	5850	5650	5450	5250	5100	5000	4850	4700	4550	4500	4400	4350	4300	4200	4150	4100	4000		
					(6.3)	(6.8)	16	24	30	34	37	40	43	45	47	49	51	52	54	55	56	57	59	59	61		
8.0							5650	5150	5000	5000	4900	4700	4550	4450	4300	4200	4100	4050	3950	3900	3850	3800	3750	3700	3650		
							(7.3)	(7.8)	15	23	28	33	36	39	41	44	46	48	49	51	52	53	55	56	57		
9.0									4750	4400	4250	4250	4150	4000	3900	3800	3650	3650	3600	3550	3500	3450	3400	3350	3300		
									(8.3)	(8.8)	14	22	27	31	35	37	40	42	44	46	48	49	51	52	53		
10											4050	3800	3700	3700	3550	3450	3300	3300	3250	3200	3150	3150	3100	3050	3000		
											(9.3)	(9.8)	14	21	26	30	34	36	39	41	43	45	46	48	50		
11														3500	3250	3200	3200	3050	3000	2950	2900	2900	2850	2850	2750		
														(10.3)	(10.8)	13	20	26	29	32	35	37	40	42	45		
12															3050	2850	2800	2800	2750	2700	2650	2600	2600	2550	2550		
															(11.3)	(11.8)	14	20	24	28	31	34	36	39	41		
13																	2650	2550	2500	2500	2450	2400	2400	2350	2350		
																	(12.4)	(12.8)	12	19	24	27	30	33	36		
14																			2400	2300	2300	2300	2250	2200	2150		
																			(13.3)	(13.8)	12	18	23	27	30		
15																					2200	2100	2100	2100	2000		
																					(14.3)	(14.8)	12	18	24		
16.4																							2000	1950	1850		
																							(15.3)	(15.8)	(16.4)		

NOTE : WEIGHT OF HOOKS, BLOCKS & OTHER
LOAD HANDLING DEVICES SHALL BE ADDED
TO THE WEIGHT OF THE LOAD

MAC-25 OFFSET HEAD TOP POSITION LOAD CHART - 10 DEG

LMI DUTY

304

STANDARD 1500 KG COUNTERWEIGHT (PLMXF2009) + EXTRA 2160 KG COUNTERWEIGHT (PLMXF2019-) ON REAR OF CRANE - SPRING LOCKOUTS ENGAGED



RC IN KILOGRAMS FOR SLEW ANGLES OF 10 DEGREES OR LESS EITHER

RC ABOVE BOLD RED LINE ARE STRUCTURAL



SIDE OF STRAIGHT AHEAD (INDICATED BY GREEN LED ON DASH).

RC ARE BASED ON FIRM LEVEL GROUND (1% SLOPE (0.6 DEG) AS PER AS1418.5)

BOOM ANGLE - UNDEFLECTED (REF.)

WITH TYRES INFLATED AS PER NOTES

NOTE : VALUES IN BRACKETS () ARE ACTUAL RADIUS AT ZERO DEG. BOOM ANGLE.

LIFT & CARRY - THE RC SHALL BE CARRIED WITH THE MINIMUM BOOM LENGTH & AS

RC ARE BASED ON 66.6% STABILITY & STRENGTH

CLOSE TO THE GROUND AS POSSIBLE AT SPEEDS NOT IN EXCESS OF 0.4 m/s (1.44 km/h)

Radius in Metres	BOOM PIVOT TO EDGE OF SHEAVE - THIRD BOOM RETRACTED (metres)															THIRD BOOM EXTENDING (metres)											
	6.82	7.00	7.50	8.00	8.50	9.00	9.50	10.00	10.50	11.00	11.50	12.00	12.50	13.00	13.50	14.00	14.50	15.02	15.50	16.00	16.50	17.00	17.50	18.00	18.50	19.12	
1.4	8400	8400	8400	8400	8400	8400	8400																				
	52	53	56	58	60	62	64																				
2.0	8400	8400	8400	8400	8400	8400	8400	8400	8400	8400																	
	45	47	50	53	56	58	60	61	63	64																	
2.5	8400	8400	8400	8400	8400	8400	8400	8400	8400	8400	8400	8400															
	39	41	45	49	52	54	56	58	60	61	63	64															
3.0	8400	8400	8400	8400	8400	8400	8400	8400	8400	8400	8400	8400	8400	8400													
	32	34	40	44	47	50	53	55	57	58	60	61	63	64	65												
3.5	8400	8400	8400	8400	8400	8400	8400	8400	8400	8400	8400	8400	8400	8400	8400	8400											
	24	27	33	38	42	46	49	51	53	55	57	59	60	61	62	63	64										
4.0	8400	8400	8400	8400	8400	8400	8400	8400	8400	8400	8400	8400	8400	8400	8400	8400	8400	8400									
	(4.1)	16	26	32	37	41	45	47	50	52	54	56	57	59	60	61	62	63	64								
5.0		8400	8400	8400	8400	8400	8400	8400	8400	8400	8400	8400	8400	8400	8400	8400	8400	8400	8400	8400	8300	8200	8050	7950			
		(4.3)	(4.8)	15	24	30	35	39	42	45	48	50	52	53	55	56	58	59	60	61	62	63	64	65			
6.0				8400	8400	8150	8150	8150	8100	8100	8050	8050	8050	8050	8000	8000	8000	7800	7650	7500	7400	7250	7150	7050	6950	6300	
				(5.3)	(5.8)	14	23	29	34	37	40	43	46	48	50	51	53	54	56	57	58	59	60	61	62	63	
7.0						7700	7000	6750	6750	6750	6700	6700	6700	6700	6650	6650	6650	6650	6650	6700	6650	6500	6450	6350	6250	5850	
						(6.3)	(6.8)	14	22	28	32	36	39	41	44	46	48	50	51	53	54	55	56	57	58	59	
8.0								6400	5900	5700	5700	5700	5700	5650	5650	5650	5650	5600	5650	5700	5700	5750	5800	5750	5650	5450	
								(7.3)	(7.8)	13	21	27	31	34	37	40	42	44	46	48	49	51	52	53	55	56	
9.0										5450	5050	4900	4900	4850	4850	4850	4850	4850	4850	4900	4950	4950	5000	5000	5050	5050	
										(8.3)	(8.8)	12	20	25	30	33	36	39	41	43	45	46	48	49	51	52	
10											4700	4350	4250	4250	4200	4200	4200	4200	4250	4250	4300	4350	4350	4400	4400	4450	
											(9.3)	(9.8)	12	19	25	29	32	35	37	40	42	43	43	45	47	48	
11														4050	3800	3700	3700	3700	3700	3700	3750	3800	3800	3850	3850	3900	3900
														(10.3)	(10.8)	12	19	24	28	31	34	36	38	40	42	44	
12																3550	3350	3250	3300	3300	3350	3400	3400	3450	3450	3500	
																(11.3)	(11.8)	12	18	23	27	30	33	35	37	40	
13																	3150	3000	2950	3000	3000	3050	3050	3100	3100		
																(12.3)	(12.8)	11	18	22	26	29	32	35	35		
14																				2850	2700	2700	2700	2750	2800	2800	
																				(13.3)	(13.8)	11	17	22	25	29	
15																						2600	2500	2450	2500	2550	
																						(14.3)	(14.8)	10	17	22	
16.45																								2400	2300	2200	
																								(15.3)	(15.8)	(16.5)	

MAC-25 OFFSET HEAD TOP POSITION LOAD CHART - 40 DEG

LMI DUTY

304

STANDARD 1500 KG COUNTERWEIGHT (PLMXF2009) + EXTRA 2160 KG COUNTERWEIGHT (PLMXF2019-) ON REAR OF CRANE - SPRING LOCKOUTS ENGAGED

█ RC IN KILOGRAMS FOR SLEW ANGLES OF GREATER THAN 10 DEGREES UP TO 40 DEGREES EITHER SIDE OF STRAIGHT AHEAD (INDICATED BY RED LED ON DASH).
▭ BOOM ANGLE - UNDEFLECTED (REF.)

RC ABOVE BOLD RED LINE ARE STRUCTURAL
 RC ARE BASED ON FIRM LEVEL GROUND (1% SLOPE (0.6 DEG) AS PER AS1418.5) WITH TYRES INFLATED AS PER NOTES
 LIFT & CARRY - THE RC SHALL BE CARRIED WITH THE MINIMUM BOOM LENGTH & AS CLOSE TO THE GROUND AS POSSIBLE AT SPEEDS NOT IN EXCESS OF 0.4 m/s (1.44 km/h)

NOTE : VALUES IN BRACKETS () ARE ACTUAL RADIUS AT ZERO DEG. BOOM ANGLE.
 RC ARE BASED ON 66.6% STABILITY & STRENGTH

Radius in Metres	BOOM PIVOT TO EDGE OF SHEAVE - THIRD BOOM RETRACTED (metres)															THIRD BOOM EXTENDING (metres)										
	6.82	7.00	7.50	8.00	8.50	9.00	9.50	10.00	10.50	11.00	11.50	12.00	12.50	13.00	13.50	14.00	14.50	15.02	15.50	16.00	16.50	17.00	17.50	18.00	18.50	19.12
1.4	8400	8400	8400	8400	8400	8400	8400																			
	52	53	56	58	60	62	64																			
2.0	8400	8400	8400	8400	8400	8400	8400	8400	8400	8400																
	45	47	50	53	56	58	60	61	63	64																
2.5	8400	8400	8400	8400	8400	8400	8400	8400	8400	8400	8400	8400														
	39	41	45	49	52	54	56	58	60	61	63	64														
3.0	8400	8400	8400	8400	8400	8400	8400	8400	8400	8400	8400	8400	8400	8350	8100											
	32	34	40	44	47	50	53	55	57	58	60	61	63	64	65											
3.5	8400	8400	8400	8400	8400	8400	8400	8400	8400	8400	8400	8100	7800	7550	7350	7100										
	24	27	33	38	42	46	49	51	53	55	57	59	60	61	62	63	64									
4.0	8400	8400	8400	8400	8400	8400	8400	8400	8400	8400	8150	7850	7600	7300	7100	6850	6650	6450	6350							
	(4.1)	16	26	32	37	41	45	47	50	52	54	56	57	59	60	61	62	63	64							
5.0		8400	8400	8400	8400	8400	8400	8100	7750	7500	7200	6950	6700	6450	6250	6050	5900	5700	5600	5500	5400	5300	5200	5100		
		(4.3)	(4.8)	15	24	30	35	39	42	45	48	50	52	53	55	56	58	59	60	61	62	63	64	65		
6.0			8400	7500	7200	7200	7100	6800	6550	6300	6100	5950	5750	5550	5400	5200	5050	5000	4900	4800	4750	4650	4600	4500	4400	
			(5.3)	(5.8)	14	23	29	34	37	40	43	46	48	50	51	53	54	56	57	58	59	60	61	62	63	
7.0				6800	6150	5950	5900	5850	5600	5400	5250	5100	4950	4800	4650	4550	4450	4400	4300	4250	4200	4100	4050	4000		
				(6.3)	(6.8)	14	22	28	32	36	39	41	44	46	48	50	51	53	54	55	56	57	58	59		
8.0					5650	5150	5000	5000	4900	4700	4550	4400	4300	4150	4050	4000	3950	3900	3800	3750	3700	3650	3600	3500		
					(7.3)	(7.8)	13	21	27	31	34	37	40	42	44	46	48	49	51	52	53	55	56			
9.0								4750	4400	4250	4250	4150	4000	3850	3750	3650	3600	3550	3500	3450	3400	3400	3350	3300		
								(8.3)	(8.8)	12	20	25	30	33	36	39	41	43	45	46	48	49	51	52		
10									4050	3750	3650	3650	3550	3400	3300	3250	3200	3200	3150	3100	3100	3050	3000	3000		
									(9.3)	(9.8)	12	19	25	29	32	35	37	40	42	43	45	47	48			
11													3500	3250	3150	3150	3050	3000	2950	2900	2850	2850	2800	2800	2750	
													(10.3)	(10.8)	12	19	24	28	31	34	36	38	40	42	44	
12															3050	2850	2750	2800	2700	2650	2650	2600	2550	2550	2500	
															(11.3)	(11.8)	12	18	23	27	30	33	35	37	40	
13																2650	2550	2500	2500	2450	2400	2400	2350	2300	2300	
															(12.3)	(12.8)	11	18	22	26	29	32	35	38		
14																		2400	2300	2300	2300	2200	2200	2150	2150	
																	(13.3)	(13.8)	11	17	22	25	29	32		
15																				2200	2100	2100	2050	2000	2000	
																			(14.3)	(14.8)	10	17	22	25		
16.45																							2000	1950	1850	
																						(15.3)	(15.8)	(16.5)		

MAC-25 3m FLYJIB TOP POSITION AT 0 DEG OFFSET LOAD CHART

COUNTERWEIGHT ON REAR OF CRANE - SPRING LOCKOUTS ENGAGED

LMI DUTY

305

PIVOT TO FLY JIB MAX LENGTH 21.4m	
MAX RADIUS	SWL
6.10	1500
	65
7.76	1500
	60
9.34	1200
	55
10.83	1200
	50
12.22	970
	45
13.49	970
	40
14.65	850
	35
15.67	850
	30
16.55	770
	25
17.29	770
	20
17.88	750
	15
18.31	750
	10
18.58	750
	5
18.69	750
	0



S.W.L IN KILOGRAMS FOR SLEW ANGLES UP TO 40

DEGREES EITHER SIDE OF STRAIGHT AHEAD (INDICATED BY RED LED ON DASH).



BOOM ANGLE - UNDEFLECTED (REF.)

NOTE : VALUES IN BRACKETS () ARE ACTUAL RADIUS AT ZERO DEG. BOOM ANGLE.
SWL IS AT THIS RADIUS

SPRING LOCKOUTS ARE TO BE ENGAGED FOR ALL LIFTING OPERATIONS

S.W.L. ARE BASED ON 66.6% STABILITY & STRENGTH

ALL FLYJIB S.W.L.'S ARE STRUCTURAL

S.W.L. ARE BASED ON FIRM LEVEL GROUND (1% SLOPE (0.6 DEG) AS PER AS1418.5)

WITH TYRES INFLATED AS PER NOTES

LIFT & CARRY - THE S.W.L. SHALL BE CARRIED WITH THE MINIMUM BOOM LENGTH & AS
CLOSE TO THE GROUND AS POSSIBLE AT SPEEDS NOT IN EXCESS OF 0.4 M/SEC (1.44 KM/HR)

FLYJIB S.W.L.'S AND RADII ARE BASED ON FULLY EXTENDED BOOM.

FOR OPERATION WITH THE BOOM PART OR FULLY RETRACTED

THE SWL WILL BE BASED ON THE BOOM ANGLE, NOT THE ACTUAL RADIUS.

NOTE : WEIGHT OF HOOKS, BLOCKS & OTHER
LOAD HANDLING DEVICES SHALL BE ADDED
TO THE WEIGHT OF THE LOAD

MAC-25 3m FLYJIB TOP POSITION AT 12.5 DEG OFFSET LOAD CHART

COUNTERWEIGHT ON REAR OF CRANE - SPRING LOCKOUTS ENGAGED

LMI DUTY

306

PIVOT TO FLY JIB MAX LENGTH 21.4m	
MAX RADIUS	SWL
6.60	1300
	65
8.23	1300
	60
9.78	1120
	55
11.24	1120
	50
12.59	920
	45
13.83	920
	40
14.94	820
	35
15.92	820
	30
16.76	770
	25
17.45	770
	20
17.99	750
	15
18.37	750
	10
18.59	750
	5
18.65	750
	0



S.W.L IN KILOGRAMS FOR SLEW ANGLES UP TO 40 DEGREES EITHER SIDE OF STRAIGHT AHEAD (INDICATED BY RED LED ON DASH).



BOOM ANGLE - UNDEFLECTED (REF.)

NOTE : VALUES IN BRACKETS () ARE ACTUAL RADIUS AT ZERO DEG. BOOM ANGLE.

SWL IS AT THIS RADIUS

SPRING LOCKOUTS ARE TO BE ENGAGED FOR ALL LIFTING OPERATIONS

S.W.L. ARE BASED ON 66.6% STABILITY & STRENGTH

ALL FLYJIB S.W.L.'S ARE STRUCTURAL

S.W.L. ARE BASED ON FIRM LEVEL GROUND (1% SLOPE (0.6 DEG) AS PER AS1418.5)

WITH TYRES INFLATED AS PER NOTES

LIFT & CARRY - THE S.W.L. SHALL BE CARRIED WITH THE MINIMUM BOOM LENGTH & AS

CLOSE TO THE GROUND AS POSSIBLE AT SPEEDS NOT IN EXCESS OF 0.4 M/SEC (1.44 KM/HR)

FLYJIB S.W.L.'S AND RADII ARE BASED ON FULLY EXTENDED BOOM.

FOR OPERATION WITH THE BOOM PART OR FULLY RETRACTED

THE SWL WILL BE BASED ON THE BOOM ANGLE, NOT THE ACTUAL RADIUS.

**NOTE : WEIGHT OF HOOKS, BLOCKS & OTHER
LOAD HANDLING DEVICES SHALL BE ADDED
TO THE WEIGHT OF THE LOAD**

MAC-25 4m FLYJIB TOP POSITION AT 5 DEG OFFSET LOAD CHART

COUNTERWEIGHT ON REAR OF CRANE - SPRING LOCKOUTS ENGAGED

LMI DUTY

307

PIVOT TO FLY JIB MAX LENGTH 22.48m	
MAX RADIUS	SWL
6.85	700
	65
8.58	600
	60
10.23	600
	55
11.77	600
	50
13.21	600
	45
14.53	500
	40
15.72	500
	35
16.77	500
	30
17.67	500
	25
18.42	500
	20
19.00	500
	15
19.43	500
	10
19.68	500
	5
19.77	500
	0



S.W.L IN KILOGRAMS FOR SLEW ANGLES UP TO 40 DEGREES EITHER SIDE OF STRAIGHT AHEAD (INDICATED BY RED LED ON DASH).



BOOM ANGLE - UNDEFLECTED (REF.)

NOTE : VALUES IN BRACKETS () ARE ACTUAL RADIUS AT ZERO DEG. BOOM ANGLE.
SWL IS AT THIS RADIUS

SPRING LOCKOUTS ARE TO BE ENGAGED FOR ALL LIFTING OPERATIONS

S.W.L. ARE BASED ON 66.6% STABILITY & STRENGTH

ALL FLYJIB S.W.L.'S ARE STRUCTURAL

S.W.L. ARE BASED ON FIRM LEVEL GROUND (1% SLOPE (0.6 DEG) AS PER AS1418.5)

WITH TYRES INFLATED AS PER NOTES

LIFT & CARRY - THE S.W.L. SHALL BE CARRIED WITH THE MINIMUM BOOM LENGTH & AS CLOSE TO THE GROUND AS POSSIBLE AT SPEEDS NOT IN EXCESS OF 0.4 M/SEC (1.44 KM/HR)

FLYJIB S.W.L.'S AND RADII ARE BASED ON FULLY EXTENDED BOOM.

FOR OPERATION WITH THE BOOM PART OR FULLY RETRACTED

THE SWL WILL BE BASED ON THE BOOM ANGLE, NOT THE ACTUAL RADIUS.

NOTE : WEIGHT OF HOOKS, BLOCKS & OTHER
LOAD HANDLING DEVICES SHALL BE ADDED
TO THE WEIGHT OF THE LOAD

MAC-25 4m FLYJIB BOTTOM POSITION AT 17.5 DEG OFFSET LOAD CHART

COUNTERWEIGHT ON REAR OF CRANE - SPRING LOCKOUTS ENGAGED

LMI DUTY

308

PIVOT TO FLY JIB MAX LENGTH 22.41m	
MAX RADIUS	SWL
7.82	600
	65
9.50	600
	60
11.09	600
	55
12.57	500
	50
13.94	500
	45
15.18	500
	40
16.29	500
	35
17.25	500
	30
18.07	500
	25
18.72	500
	20
19.22	500
	15
19.55	500
	10
19.70	500
	5
19.70	500
	0



S.W.L IN KILOGRAMS FOR SLEW ANGLES UP TO 40 DEGREES EITHER SIDE OF STRAIGHT AHEAD (INDICATED BY RED LED ON DASH).



BOOM ANGLE - UNDEFLECTED (REF.)

NOTE : VALUES IN BRACKETS () ARE ACTUAL RADIUS AT ZERO DEG. BOOM ANGLE.
SWL IS AT THIS RADIUS

SPRING LOCKOUTS ARE TO BE ENGAGED FOR ALL LIFTING OPERATIONS

S.W.L. ARE BASED ON 66.6% STABILITY & STRENGTH

ALL FLYJIB S.W.L.'S ARE STRUCTURAL

S.W.L. ARE BASED ON FIRM LEVEL GROUND (1% SLOPE (0.6 DEG) AS PER AS1418.5)

WITH TYRES INFLATED AS PER NOTES

LIFT & CARRY - THE S.W.L. SHALL BE CARRIED WITH THE MINIMUM BOOM LENGTH & AS CLOSE TO THE GROUND AS POSSIBLE AT SPEEDS NOT IN EXCESS OF 0.4 M/SEC (1.44 KM/HR)

FLYJIB S.W.L.'S AND RADII ARE BASED ON FULLY EXTENDED BOOM.

FOR OPERATION WITH THE BOOM PART OR FULLY RETRACTED

THE SWL WILL BE BASED ON THE BOOM ANGLE, NOT THE ACTUAL RADIUS.

NOTE : WEIGHT OF HOOKS, BLOCKS & OTHER
LOAD HANDLING DEVICES SHALL BE ADDED
TO THE WEIGHT OF THE LOAD

MAC-25 MAN BASKET LOAD CHART

COUNTERWEIGHT ON REAR OF CRANE - SPRING LOCKOUTS ENGAGED

LMI DUTY

309

**MAXIMUM MANBASKET SWL: 275 KG (SEE NOTE BELOW)
BASKET WEIGHT: 225 KG**

*Read and understand warning notes before
operating crane*

**NOTE: THE TOTAL WEIGHT OF THE MANBASKET PLUS
MEN AND EQUIPMENT IS NOT TO EXCEED 1/3 OF
THE SAFE WORKING LOAD AS READ ON LOAD
CHART (FALL BLOCK LOAD CHART - DUTY 201)
FOR THE BOOM LENGTH AND RADIUS BEING USED.**

MAC-25 BUTT LUG - 10 DEG. ART.

STANDARD 1500 KG COUNTERWEIGHT (PLMXF2009)

+ EXTRA 2160 KG COUNTERWEIGHT (PLMXF2019-) ON REAR OF CRANE - SPRING LOCKOUTS ENGAGED



RC IN KILOGRAMS FOR SLEW ANGLES OF 10 DEGREES OR LESS EITHER SIDE OF STRAIGHT AHEAD (INDICATED BY GREEN LED ON DASH).



BOOM ANGLE - UNDEFLECTED (REF.)

NOTE: VALUES IN BRACKETS () ARE ACTUAL RADIUS AT ZERO DEG. BOOM ANGLE. RC IS AT THIS RADIUS

MAC-25 BUTT LUG - 40 DEG. ART.



RC IN KILOGRAMS FOR SLEW ANGLES OF GREATER THAN 10 DEGREES UP TO 40 DEGREES EITHER SIDE OF STRAIGHT AHEAD (INDICATED BY RED LED ON DASH).



BOOM ANGLE - UNDEFLECTED (REF.)

NOTE: VALUES IN BRACKETS () ARE ACTUAL RADIUS AT ZERO DEG. BOOM ANGLE. RC IS AT THIS RADIUS

RC ARE BASED ON 66.6% STABILITY & STRENGTH - RC ABOVE BOLD RED LINE ARE STRUCTURAL

RC ARE BASED ON FIRM, LEVEL GROUND (1% SLOPE (0.6 DEG) AS PER AS1418.5) WITH TYRES INFLATED AS PER NOTES

LIFT & CARRY - THE RC SHALL BE CARRIED WITH THE MINIMUM BOOM LENGTH & AS CLOSE TO THE GROUND AS POSSIBLE AT SPEEDS NOT IN EXCESS OF 0.4 m/s (1.44 km/h)

NOTE : WEIGHT OF HOOKS, BLOCKS & OTHER LOAD HANDLING DEVICES SHALL BE ADDED TO THE WEIGHT OF THE LOAD

Radius in Metres	Boom Length (metres)
	4.81
1.4	25000
	32
1.5	25000
	30
1.6	24650
	27
1.7	24200
	24
1.8	23800
	21
1.9	23400
	18
2.1	22600
	0

NOTE : WEIGHT OF HOOKS, BLOCKS & OTHER LOAD HANDLING DEVICES SHALL BE ADDED TO THE WEIGHT OF THE LOAD

Radius in Metres	Boom Length (metres)
	4.81
1.4	25000
	32
1.5	25000
	30
1.6	24650
	27
1.7	24200
	24
1.8	23800
	21
1.9	23400
	18
2.1	22050
	0

MAC25 LUG 1 LOAD CHART - 10 DEG. ART.

STANDARD 1500 KG COUNTERWEIGHT (PLMXF2009)

+ EXTRA 2160 KG COUNTERWEIGHT (PLMXF2019-) ON REAR OF CRANE - SPRING LOCKOUTS ENGAGED



RC IN KILOGRAMS FOR SLEW ANGLES OF 10 DEGREES OR LESS EITHER SIDE OF STRAIGHT AHEAD (INDICATED BY GREEN LED ON DASH).



BOOM ANGLE - UNDEFLECTED (REF.)

NOTE: VALUES IN BRACKETS () ARE ACTUAL RADIUS AT ZERO DEG. BOOM ANGLE RC IS AT THIS RADIUS

MAC25 LUG 1 LOAD CHART - 40 DEG. ART.



RC IN KILOGRAMS FOR SLEW ANGLES OF GREATER THAN 10 DEGREES UP TO 40 DEGREES EITHER SIDE OF STRAIGHT AHEAD (INDICATED BY RED LED ON DASH).



BOOM ANGLE - UNDEFLECTED (REF.)

NOTE: VALUES IN BRACKETS () ARE ACTUAL RADIUS AT ZERO DEG. BOOM ANGLE RC IS AT THIS RADIUS

RC ARE BASED ON 66.6% STABILITY & STRENGTH - RC ABOVE BOLD RED LINE ARE STRUCTURAL

RC ARE BASED ON FIRM, LEVEL GROUND (1% SLOPE (0.6 DEG) AS PER AS1418.5) WITH TYRES INFLATED AS PER NOTES

LIFT & CARRY - THE RC SHALL BE CARRIED WITH THE MINIMUM BOOM LENGTH & AS CLOSE TO THE GROUND AS POSSIBLE AT SPEEDS NOT IN EXCESS OF 0.4 m/s (1.44 km/h)

NOTE : WEIGHT OF HOOKS, BLOCKS & OTHER LOAD HANDLING DEVICES SHALL BE ADDED TO THE WEIGHT OF THE LOAD

RADIUS IN METRES	BOOM PIVOT TO LUG 1, 1st EXTENSION, THIRD EXTENSION RETRACTED									
	(metres)									
	5.36	5.50	6.00	6.50	7.00	7.50	8.00	8.50	9.00	9.46
1.4	25000	25000	25000	25000	25000	25000	25000	25000	25000	24000
	40	42	47	51	54	57	59	61	63	64
2	23900	23850	23650	23500	23300	23150	22950	22750	22600	21350
	29	31	38	44	48	51	54	56	59	60
2.5	21000	20950	20700	20450	20250	20050	19900	19750	19600	19500
	14	19	30	37	42	46	49	52	55	57
3	18600	18000	16900	16700	16550	16400	16250	16100	16000	15900
	(2.7)	(2.8)	18	29	35	41	45	48	51	53
3.5			15200	14050	13900	13750	13600	13500	13400	13300
			(3.3)	17	28	34	39	43	46	49
4				12750	11900	11750	11650	11550	11450	11350
				(3.8)	17	27	33	38	42	45
5					10850	9350	8850	8800	8700	8650
					(4.3)	(4.8)	16	25	31	36
6							8150	7150	6850	6800
							(5.3)	(5.8)	15	23
6.8									6300	5650
									(6.3)	(6.8)

RADIUS IN METRES	BOOM PIVOT TO LUG 1, 1st EXTENSION, THIRD EXTENSION RETRACTED									
	(metres)									
	5.36	5.50	6.00	6.50	7.00	7.50	8.00	8.50	9.00	9.46
1.4	22600	21750	19350	17600	16150	15000	14000	13200	12450	11800
	40	42	47	51	54	57	59	61	63	64
2	23800	22900	18750	16600	15050	13850	12850	12000	11300	10700
	29	31	38	44	48	51	54	56	59	60
2.5	18700	18650	18400	16800	14250	13000	11950	11150	10450	9900
	14	19	30	37	42	46	49	52	55	57
3	17500	16450	15000	14800	13950	12950	11200	10350	9650	9150
	(2.7)	(2.8)	18	29	35	41	45	48	51	53
3.5			13450	12400	12250	11750	10950	9650	8950	8450
			(3.3)	17	28	34	39	43	46	49
4				11200	10450	10350	10000	9350	8800	7850
				(3.8)	17	27	33	38	42	45
5					9500	8150	7700	7650	7400	7000
					(4.3)	(4.8)	16	25	31	36
6							7050	6150	5900	5850
							(5.3)	(5.8)	15	23
6.8									5400	4800
									(6.3)	(6.8)

**THIS PAGE HAS BEEN
INTENTIONALLY LEFT BLANK**

MAC-25 LUG 2 LOAD CHART - 10 DEG. ART.

LMI DUTY

312

STANDARD 1500 KG COUNTERWEIGHT (PLMXF2009)

+ EXTRA 2160 KG COUNTERWEIGHT (PLMXF2019-) ON REAR OF CRANE - SPRING LOCKOUTS ENGAGED



RC IN KILOGRAMS FOR SLEW ANGLES OF 10 DEGREES OR LESS EITHER

RC ARE BASED ON 66.6% STABILITY & STRENGTH

SIDE OF STRAIGHT AHEAD (INDICATED BY GREEN LED ON DASH).

RC ABOVE BOLD RED LINE ARE STRUCTURAL



BOOM ANGLE - UNDEFLECTED (REF.)

RC ARE BASED ON FIRM LEVEL GROUND (1% SLOPE (0.6 DE

NOTE: VALUES IN BRACKETS () ARE ACTUAL RADIUS AT ZERO DEG. BOOM ANGLE.

AS PER AS1418.5) WITH TYRES INFLATED AS PER NOTES

ENSURE WINCH ROPE IS FULLY TENSIONED

LIFT & CARRY - THE RC SHALL BE CARRIED WITH THE MINIMUM BOOM LENGTH & AS

CLOSE TO THE GROUND AS POSSIBLE AT SPEEDS NOT IN EXCESS OF 0.4 m/s (1.44 km/h)

Radius in Metres	BOOM PIVOT TO LUG 2, 2nd EXTENSION, THIRD EXTENSION RETRACTED (metres)																	
	5.57	6.00	6.50	7.00	7.50	8.00	8.50	9.00	9.50	10.00	10.50	11.00	11.50	12.00	12.50	13.00	13.50	13.77
1.4	25000	25000	25000	25000	25000	25000	25000	25000	25000									
	42	46	50	54	57	59	61	63	64									
2	24150	24100	24000	23950	23900	23850	23800	23700	23650	23600	21850	19400						
	32	38	43	47	51	54	56	58	60	62	63	64						
2.5	21150	21150	21150	21100	21100	21050	21050	21000	21000	19950	17700	16550	15650					
	20	29	36	42	46	49	52	54	57	58	60	62	63	64				
3	17900	17350	17350	17350	17300	17300	17300	17300	17250	17250	17250	16300	15200	14400	13600	12900		
	(2.9)	18	28	35	40	44	48	50	53	55	57	59	60	61	63	64		
3.5		15600	14650	14650	14650	14600	14600	14600	14600	14550	14550	14550	14050	13300	12600	11900	11250	10900
		(3.3)	17	27	34	39	43	46	49	51	54	55	57	59	60	61	62	63
4			13350	12600	12600	12600	12600	12600	12550	12550	12550	12550	12550	12350	11700	11050	10450	10150
			(3.8)	16	26	33	38	42	45	48	50	52	54	56	57	59	60	61
5				11600	10200	9750	9750	9750	9750	9750	9750	9750	9700	9700	9700	9650	9100	8800
				(4.3)	(4.8)	15	25	31	36	39	43	45	48	50	52	53	55	56
6						9050	8150	7850	7850	7850	7850	7850	7850	7850	7850	7850	7850	7800
						(5.3)	(5.8)	14	23	29	34	37	41	43	46	48	50	51
7								7350	6700	6500	6500	6500	6500	6500	6500	6500	6500	6500
								(6.3)	(6.8)	14	22	28	32	36	39	42	44	45
8										6100	5600	5500	5500	5500	5500	5500	5500	5500
										(7.3)	(7.8)	13	21	27	31	34	37	39
9												5150	4750	4700	4700	4700	4700	4700
												(8.3)	(8.8)	12	20	26	30	32
10		NOTE : WEIGHT OF HOOKS, BLOCKS & OTHER LOAD HANDLING DEVICES SHALL BE ADDED TO THE WEIGHT OF THE LOAD												4450	4100	4050	4050	4050
11																3850	3550	3550
																(10.3)	(10.8)	6
11.1																		3450
																		(11.1)

MAC-25 LUG 2 LOAD CHART - 40 DEG. ART.

LMI DUTY

312

STANDARD 1500 KG COUNTERWEIGHT (PLMXF2009)

+ EXTRA 2160 KG COUNTERWEIGHT (PLMXF2019-) ON REAR OF CRANE - SPRING LOCKOUTS ENGAGED



RC IN KILOGRAMS FOR SLEW ANGLES OF GREATER THAN 10 DEGREES UP TO 40 DEGREES EITHER SIDE OF STRAIGHT AHEAD (INDICATED BY RED LED ON DASH).

RC ARE BASED ON 66.6% STABILITY & STRENGTH

RC ABOVE BOLD RED LINE ARE STRUCTURAL



BOOM ANGLE - UNDEFLECTED (REF.)

RC ARE BASED ON FIRM LEVEL GROUND (1% SLOPE (0.6 DE

NOTE: VALUES IN BRACKETS () ARE ACTUAL RADIUS AT ZERO DEG. BOOM ANGLE.

AS PER AS1418.5) WITH TYRES INFLATED AS PER NOTES

ENSURE WINCH ROPE IS FULLY TENSIONED

LIFT & CARRY - THE RC SHALL BE CARRIED WITH THE MINIMUM BOOM LENGTH & AS

CLOSE TO THE GROUND AS POSSIBLE AT SPEEDS NOT IN EXCESS OF 0.4 m/s (1.44 km/h)

Radius in Metres	BOOM PIVOT TO LUG 2, 2nd EXTENSION, THIRD EXTENSION RETRACTED (metres)																	
	5.57	6.00	6.50	7.00	7.50	8.00	8.50	9.00	9.50	10.00	10.50	11.00	11.50	12.00	12.50	13.00	13.50	13.77
1.4	21500	19650	18000	16700	15650	14750	13950	13250	12650									
	42	46	50	54	57	59	61	63	64									
2	22700	19050	17050	15650	14500	13600	12850	12200	11600	11100	10650	10200						
	32	38	43	47	51	54	56	58	60	62	63	64						
2.5	18850	18850	17400	14900	13700	12800	12050	11400	10850	10350	9900	9500	9150	8850				
	20	29	36	42	46	49	52	54	57	58	60	62	63	64				
3	16200	15400	15450	14700	13800	12050	11300	10650	10100	9650	9250	8850	8550	8250	7950	7700		
	(2.9)	18	28	35	40	44	48	50	53	55	57	59	60	61	63	64		
3.5		13850	13000	13000	12600	11900	10600	10000	9450	9000	8650	8300	7950	7700	7400	7200	6950	6850
		(3.3)	17	27	34	39	43	46	49	51	54	55	57	59	60	61	62	63
4			11800	11150	11150	10950	10350	9400	8900	8450	8100	7750	7450	7200	6950	6700	6500	6400
			(3.8)	16	26	33	38	42	45	48	50	52	54	56	57	59	60	61
5				10250	9000	8600	8600	8500	8100	7750	7500	6850	6550	6350	6100	5900	5750	5650
				(4.3)	(4.8)	15	25	31	36	39	43	45	48	50	52	53	55	56
6					8000	7150	6900	6900	6800	6500	6300	6050	5600	5400	5250	5100	5000	
					(5.3)	(5.8)	14	23	29	34	37	41	43	46	48	50	51	
7							6450	5850	5650	5700	5600	5350	5200	5000	4700	4550	4450	
							(6.3)	(6.8)	14	22	28	32	36	39	42	44	45	
8									5300	4850	4750	4750	4650	4500	4350	4200	4150	
									(7.3)	(7.8)	13	21	27	31	34	37	39	
9												4450	4100	4050	4050	3950	3800	3750
												(8.3)	(8.8)	12	20	26	30	32
10		NOTE : WEIGHT OF HOOKS, BLOCKS & OTHER LOAD HANDLING DEVICES SHALL BE ADDED TO THE WEIGHT OF THE LOAD												3800	3500	3500	3500	3400
														(9.3)	(9.8)	12	19	23
11																3250	3050	3000
																(10.3)	(10.8)	6
11.1																		2900
																		(11.1)

AFTERMARKET DEPARTMENT KEY CONTACTS LIST

National Technical Support Contact 24/7

PH: 1800 837 395 (1800TEREXL)

Aftermarket Manager

Ph: +64 7 3868 9674

Customer Service Manager

Ph: +64 7 3868 9690

MANAGERS

Spare Parts	Product Support	Service	Warranty
+64 7 3868 9652	+64 7 3868 9655	+64 7 3868 9690	+64 7 3868 9657

SERVICE CONTACTS

QLD	NSW	VIC	WA
+64 7 3868 9600	+64 2 8786 4400	+64 3 9551 9164	+64 8 6254 2145

SPARE PARTS CONTACTS

QLD	NSW	VIC	WA
+64 7 3868 9600	+64 2 8786 4404	+64 3 9551 8644	+64 8 6254 2145

Please have the following information available before calling:

- ✓ Company name, contact name, phone number and e-mail
- ✓ Crane model and serial number
- ✓ Crane hours and kilometers

**A FULL LIST OF CONTACTS IS AVAILABLE ON REQUEST
PLEASE CALL YOUR NEAREST BRANCH OFFICE**